



Water cooled condensers with liquid receiver

→ CONDOR-H (horizontal) / CONDOR-V (vertical)

■ Applications

- Water cooled condensers with liquid receiver ensure cooling, condensation and storage of refrigerant in refrigerating and air conditioning installations.
- They also allow storage of the refrigerant, in order to compensate volume variations due to the opening and closing sequences of the expansion valve.
- In CO₂ subcritical installations, they can be used as a liquid receiver with exchanger to keep temperature and pressure stable.
- Heat exchange is carried out by a water circulation inside a very high performance finned copper tubing coil.
- Energy recovery: The use of a water cooled condenser CONDOR allows to heat with lower costs water circulating in the exchanger (technical hot water ...)

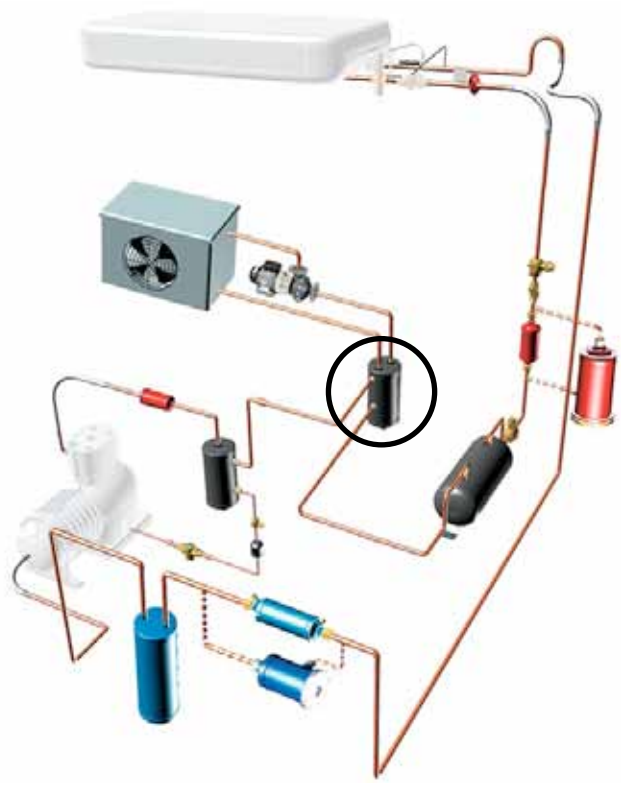
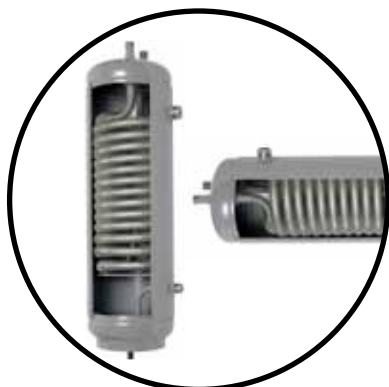

■ Functional features

- Products are compatible with CFCs, HCFCs, HFCs, CO₂s, as well as with their associated oils and additives. Products are designed for use of non-hazardous refrigerants from group 2 of PED 97/23/EC. To use CARLY components with fluids of the hydrocarbon group 1 – Propane R290, Butane R600, Isobutane R600a, Propylene R1270 – with HFOs and transcritical CO₂ and for a RANKINE organic cycle application, contact CARLY technical department.
- Product classification in CE categories is done with the PED 97/23/EC table, corresponding to a volume-based selection.
- Hermetically sealed outer steel enclosure with paint to ensure a high resistance to corrosion.
- Two ranges of water cooled condensers receivers for an installation and an operation in horizontal position for CONDOR-H and in vertical position for CONDOR-V.
- They are fitted with fastening means suited to their volume and to their weight.
- They can function with tap water, river water, tower water (treated or not), with glycol water and with refrigerants and heat transfer fluids.
- Presence of a 3/8" NPT boss on the model CONDOR-V 2500, for mounting of safety elements in accordance with the standard EN 378-2.

■ Possible customization on demand:

- Depending on the application, CARLY can transform its water cooled condensers in subcoolers.

■ CARLY advantages

- Maximum working pressure 46 bar.
- Water cooled condensers with receiver are supplied perfectly clean and dried.
- They offer both following connection possibilities for the refrigerant:
 - Outside of the connections to screw.
 - Inside of the connections to braze.
- Heat exchangers made of finned copper for very high performance.
- Low water consumptions.
- Low pressure drop on water.
- A wide range of accessories is available:
 - Rotalock stop valves, with connections to screw or to braze.
 - Rotalock connections with possibility of diameter reductions and with connections to braze.
- Reduction of the quantity of the refrigerant in the circuit compared to installations with air cooled condensers.
- GOST certified products.



Water cooled condensers with liquid receiver

→ CONDOR-H (horizontal) / CONDOR-V (vertical)

■ Warning

Before selecting or installing any component, please refer to the chapter 0 - **WARNING**.

■ General assembly precautions

The installation of a component in a refrigeration system by a skilled professional, requires some precautions:

- Some are specific to each component, and in this case, they are specified in the **RECOMMENDATIONS SPECIFIC** part defined hereafter ;
- Other are general to all CARLY components, they are presented in the chapter 115 – **GENERAL ASSEMBLY PRECAUTIONS**.
- The recommendations relating to the CARLY components for the subcritical CO₂ applications are also developed in chapter 115 – **GENERAL ASSEMBLY PRECAUTIONS**.

■ Recommendations specific to the water cooled condenser with liquid receiver CONDOR

- The water cooled condensers must be installed at the discharge of the compressors, horizontally for models CONDOR-H, vertically for models CONDOR-V and in both cases, with their feet brackets at the bottom.
- For optimal operation, refrigerant and water flow directions should be respected ("IN" tag at the inlet of each circuit).
- If sizing of the receivers is performed on the basis of the total refrigerant load, it is imperative to select receivers with an internal volume 20 % bigger, so that the gas reserve is always above the liquid level.
- It is essential to ensure a water circulation before any handling on the refrigerating circuit (risk of freezing).
- Water circulating in the heat exchangers can freeze:
 - when the installation is running, if the refrigerant pressure decreases
 - when the installation is stopped, if the ambient temperature drops.
 It is therefore recommended to install appropriate frost protection devices.
- Be sure to maintain a good cleanliness of the water circuit using appropriate and regularly changed filters.
- Use of sea water strictly prohibited.
- The connections of the water cooled condensers CONDOR have an external screw thread (sketch 1) allowing the assembly of isolating valves or Rotalock connections, and an internal bore (sketch 2) allowing the brazing of a pipe.

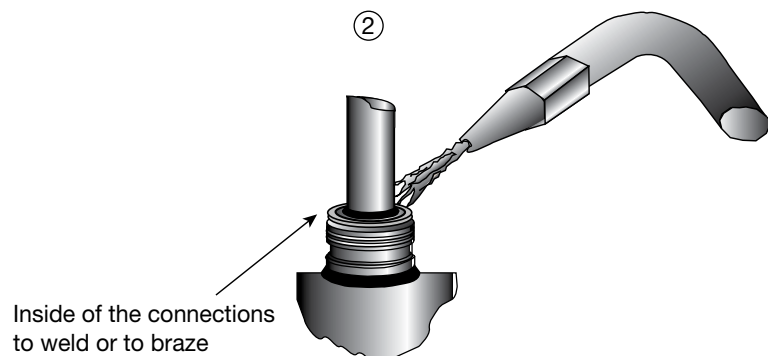
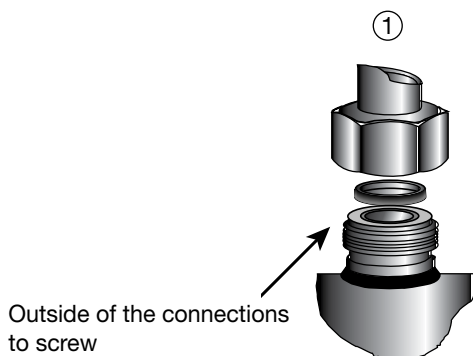



Water cooled condensers with liquid receiver

→ CONDOR-H (horizontal)

■ Quick selection table

CARLY references	Gas inlet connections R1		Liquid outlet connections R2		Water inlet W1 and outlet W2 connections mm	Condensation capacity Qk (1) kW	Water flow m ³ /h	Water pressure drop bar	Volume of refrigerant	
	Outside of connections to screw UNF inch	Inside of connections to braze ODF inch	Outside of connections to screw UNF inch	Inside of connections to braze ODF inch					Maximum storage L	Without subcooling L
CONDOR-H 150	3/4	3/8	3/4	3/8	1/2 ODF	1,45	0,10	0,01	2,9	0,27
CONDOR-H 250	3/4	3/8	3/4	3/8	1/2 ODF	2,46	0,20	0,02	2,9	0,27
CONDOR-H 500	1	1/2	3/4	3/8	1/2 ODF	5,00	0,25	0,06	4,9	0,32
CONDOR-H 750	1	1/2	3/4	3/8	1/2 ODF	7,50	0,30	0,12	4,1	0,41
CONDOR-H 1000	1	1/2	3/4	3/8	1/2 ODF	9,90	0,40	0,16	6,3	0,41

(1) Refrigerant R404A ; Δt1 = 25 K ;

Δt1 = Condensing temperature - Water inlet temperature

■ Technical features

CARLY references	Dimensions mm														
	Ø1	Ø2	Ø3	L1	L2	L3	L4	L5	L6	E1	E2	E3	E4	E5	E6
CONDOR-H 150	121,0	128	4 x Ø6,5 x 10	405	371	34	340	80	227	230	66	4	40	300	60
CONDOR-H 250	121,0	128	4 x Ø6,5 x 10	405	371	34	340	80	227	230	66	4	40	300	60
CONDOR-H 500	152,4	156	2 x Ø9 x 5,5	453	387	66	442	40	257	218	80	10	70	410	/
CONDOR-H 750	121,0	128	4 x Ø6,5 x 10	531	497	34	340	80	227	360	68	4	40	300	60
CONDOR-H 1000	152,4	156	2 x Ø9 x 5,5	565	499	66	442	40	257	348	71	10	70	410	/

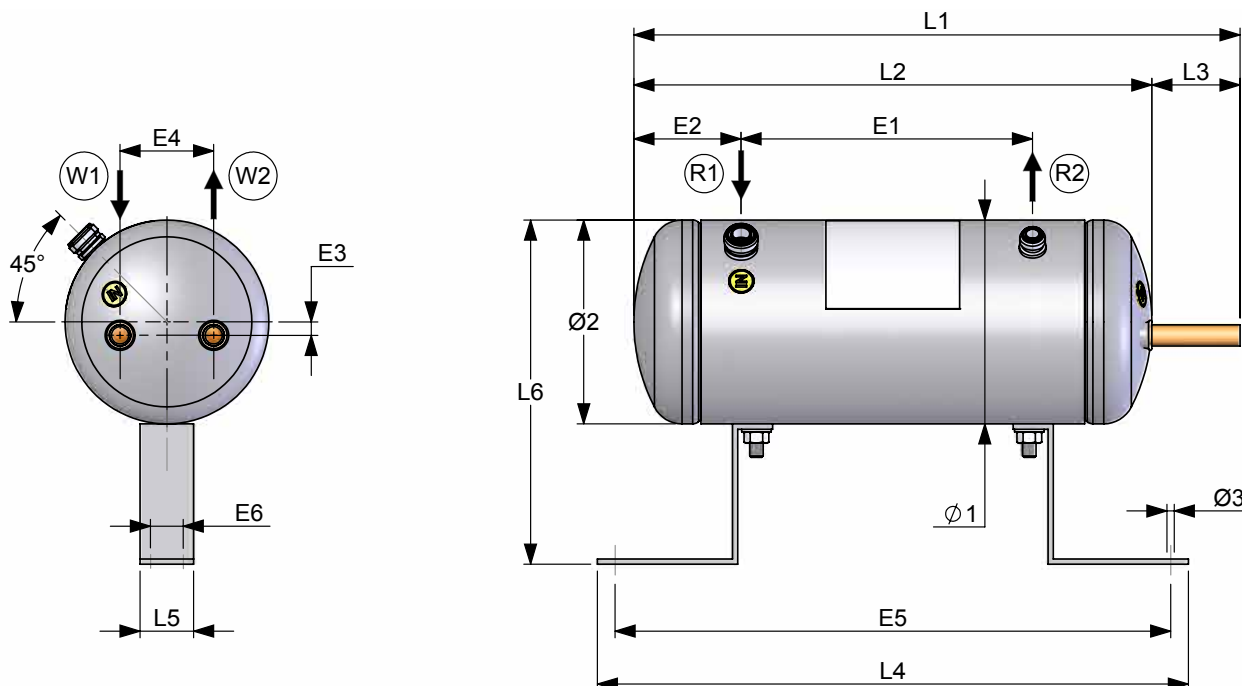



Water cooled condensers with liquid receiver

→ CONDOR-H (horizontal)

■ Technical features

CARLY references	Volume	Maximal working pressure	Heat exchanger maximal working pressure	Maximal working temperature	Minimal working temperature	Working temperature	CE Category ⁽¹⁾
	V L	PS bar	PS Ech. bar	TS maxi °C	TS mini °C	TS BT °C	
CONDOR-H 150	3,4	46	10	120	-20	/	I
CONDOR-H 250	3,2	46	10	120	-20	/	I
CONDOR-H 500	5,8	46	10	120	-20	/	II
CONDOR-H 750	4,0	46	10	120	-20	/	I
CONDOR-H 1000	7,4	46	10	120	-20	/	II

⁽¹⁾ Classification by volume, according to PED 97/23/EC (refer to chapter 0).

■ Example of selection of a CONDOR water cooled condenser with liquid receiver

The sizing of a product implies for the buyer to take into account the conditions under which the product will be used (temperature - pressure - refrigerant oil external environment). The values of the selection tables proposed in the CARLY catalogue match accurate test conditions.

- Installation operating with R404A under the following conditions⁽¹⁾:
 - $Qk_x = 7 \text{ kW}$
 - $T_k = 40 \text{ °C}$
 - $Tl_1 = 20 \text{ °C} \longrightarrow \Delta t_1 = 40 - 20 = 20\text{K}$
 - Maximum water flow = 500 l/h
 - Normal city water
- Which water cooled condenser CONDOR to choose?

1° Make corrections according to the water and the refrigerantes:

- 1-1 Correction according to fouling factor F_e (refer to page 34.5)
- 1-2 Correction according to refrigerant F_r (refer to page 34.5)

Result: $Qk = Qk_x \times F_e \times F_r = 7 \text{ kW}$

2° Report the capacity to the quick selection table, page 34.5

3° Report the maximum water flow to the quick selection table, page 34.5

4° Select the CONDOR H model.

Result:

CONDOR H -1000	→	$\Delta t_1 = 18\text{K}$
CONDOR H -750	→	$\Delta t_1 = 20\text{K}$
CONDOR H -500	→	$\Delta t_1 = 25\text{K}$

⁽¹⁾ Chapter «Abbreviations and units» (refer to chapter 113).



Water cooled condensers with liquid receiver

→ CONDOR-H (horizontal)

■ Technical features

- According to the type of water available, the condensation capacity (Q_{kx}) of the installation should be corrected in accordance to the fouling factor by the formula:

$$Q_k = Q_{kx} \times Fe$$

Water type	Fouling factor $m^2.K / W$	Correction factor Fe
Normal city water	43.10-6	1,00
Treated tower water	43.10-6	1,00
Untreated tower water	86.10-6	1,19
River water	86.10-6	1,19
Glycol water below 40 %	86.10-6	1,19
Glycol water below 70 %	172.10-6	1,56

- According to the type of refrigerant used, the condensation capacity (Q_{kx}) of the installation should be corrected in accordance to the following Fr factor by the formula:

$$Q_k = Q_{kx} \times Fr$$

Refrigerant	Correction factor Fr
R404A / R507	1,00
R 22 / R410A / R407F	0,92
R134a / R407C	0,85

■ Quick Selection Table

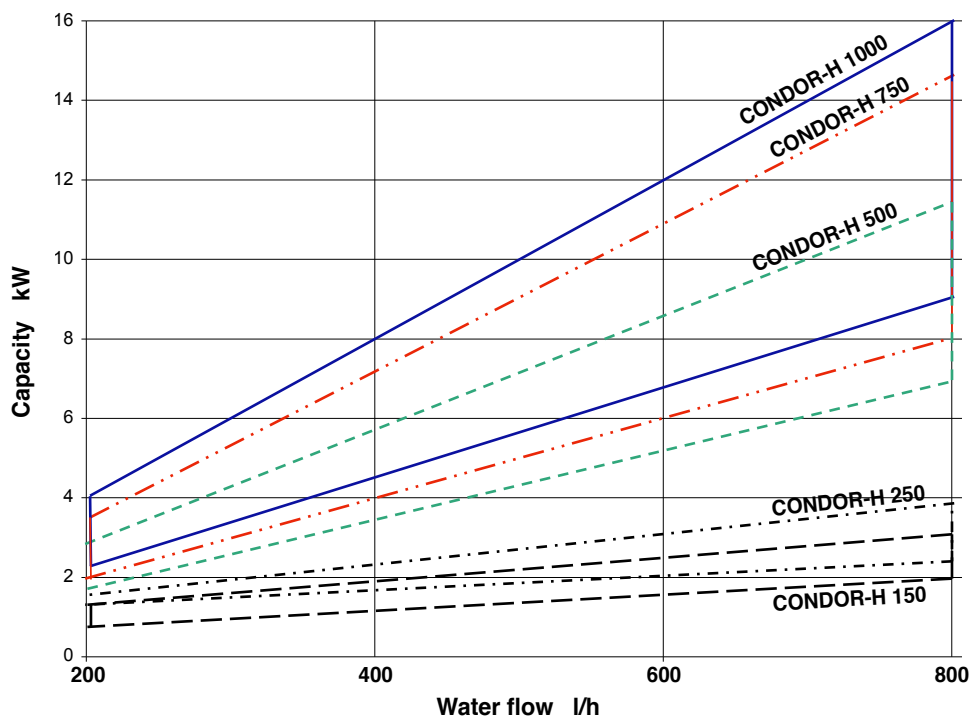

15K ≤ Δt1 ≤ 25K



Water cooled condensers with liquid receiver

→ CONDOR-H (horizontal)

■ Spares parts and options

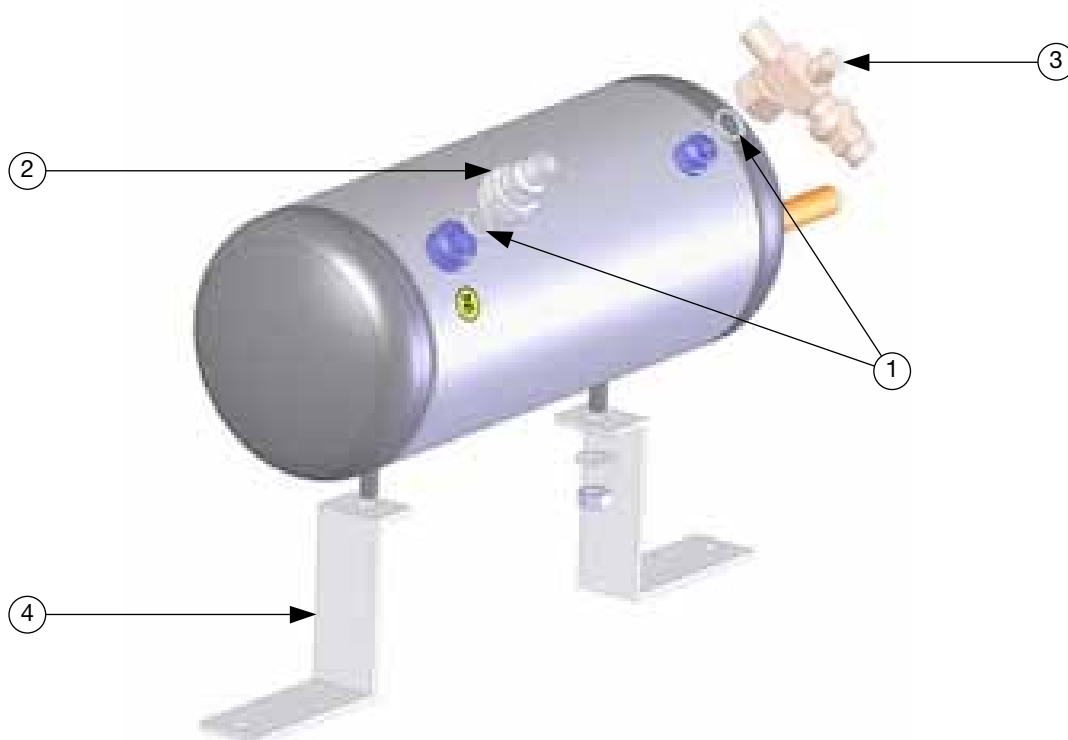

CONDOR H ⁽¹⁾	CARLY references	Part N°	Flat gasket for valves and ROTALOCK connections inch
150 - 250 - 500(S) - 750(S) - 1000(S)	CY 15580100	1	1/4" et 3/8"
500(E) - 750(E) - 1000(E)	CY 15580140	1	1/2"

⁽¹⁾ (E) = Inlet, (S) = Outlet

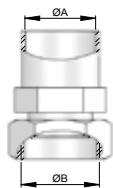

CONDOR H ⁽¹⁾	CARLY references	Part N°	ROTALOCK connections, gasket included	
			ØA outlet ODF connection inch	ØB fixing UNF connector inch
150 - 250 - 500(S) - 750(S) - 1000(S)	CY 17400000	2	1/4	3/4
150 - 250 - 500(S) - 750(S) - 1000(S)	CY 17400010	2	3/8	3/4
500(E) - 750(E) - 1000(E)	CY 17400020	2	1/2	1

⁽¹⁾ (E) = Inlet, (S) = Outlet



Water cooled condensers with liquid receiver

→ CONDOR-H (horizontal)

■ Spares parts and options

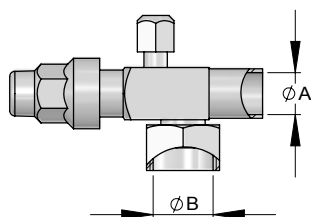

CONDOR H ⁽¹⁾	CARLY references	Part N°	ROTALOCK valve with connection to solder, gasket included	
			ØA outlet ODF valve inch	ØB fixing UNF valve inch
150 - 250 - 500(S) - 750(S) - 1000(S)	CY 19700080	3	1/4	3/4
150 - 250 - 500(S) - 750(S) - 1000(S)	CY 19700110	3	3/8	3/4
500(E) - 750(E) - 1000(E)	CY 19700120	3	1/2	1

⁽¹⁾ (E) = Inlet, (S) = Outlet

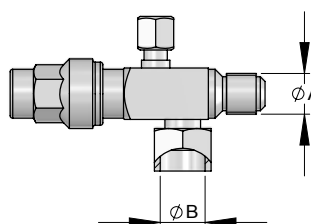

CONDOR H ⁽¹⁾	CARLY references	Part N°	ROTALOCK valve with connection to screw, gasket included	
			ØA outlet SAE valve inch	ØB fixing UNF valve inch
150 - 250 - 500(S) - 750(S) - 1000(S)	CY 19700090	3	1/4	3/4
150 - 250 - 500(S) - 750(S) - 1000(S)	CY 19700100	3	3/8	3/4
500(E) - 750(E) - 1000(E)	CY 19700140	3	1/2	1

⁽¹⁾ (E) = Inlet, (S) = Outlet

CY 37100210

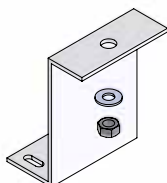

CY 37100220

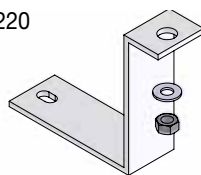

CONDOR H	CARLY references	Part N°	Description
150 - 250 - 750	CY 37100210	4	Support feet
500 - 1000	CY 37100220	4	Support feet

■ Weights and packaging

CARLY references	Unit weight kg		Packaging number of pieces
	With packaging	Without packaging	
CONDOR-H 150	5,65	5,20	1
CONDOR-H 250	8,65	8,20	1
CONDOR-H 500	11,30	11,00	1
CONDOR-H 750	7,65	7,20	1
CONDOR-H 1000	14,30	14,00	1



Water cooled condensers with liquid receiver

→ CONDOR-V (vertical)

■ Selection table

CARLY references	Gas inlet connections R1		Liquid outlet connections R2		Water inlet W1 and outlet W2 connections mm	Condensation capacity Qk kW	Water flow m ³ /h	Water pressure drop bar	Volume of refrigerant	
	Outside of connections to screw UNF inch	Inside of connections to braze ODF inch	Outside of connections to screw UNF inch	Inside of connections to braze ODF inch					Maximum storage L	Without subcooling L
CONDOR-V 100	3/4	3/8	3/4	3/8	1/2 ODF	1,11 ⁽¹⁾	0,10	0,01	2,0	1,00
CONDOR-V 150	3/4	3/8	3/4	3/8	1/2 ODF	1,52 ⁽¹⁾	0,10	0,01	2,7	1,80
CONDOR-V 240	3/4	3/8	3/4	3/8	1/2 ODF	2,39 ⁽¹⁾	0,20	0,02	2,7	1,70
CONDOR-V 500	1	1/2	3/4	3/8	1/2 ODF	4,90 ⁽¹⁾	0,30	0,07	6,1	2,50
CONDOR-V 1000	1 1/4	5/8	1	1/2	1/2 ODF	9,82 ⁽¹⁾	0,50	0,25	7,7	2,50
CONDOR-V 1400	1 1/4	5/8	1	1/2	1/2 ODF	14,56 ⁽²⁾	0,80	0,53	3,1	0,70
CONDOR-V 2500	1 3/4	7/8	1 1/4	5/8	G 3/4 M	25,50 ⁽²⁾	1,60	0,37	13,0	3,50

⁽¹⁾ Refrigerant R404A ; $\Delta t_1 = 20$ K ;

⁽²⁾ Refrigerant R404A ; $\Delta t_1 = 25$ K ;

$\Delta t_1 =$ Condensing temperature - Water inlet temperature

For more details on the selection of condensers, refer to pages 34-10 to 34-15.



Water cooled condensers with liquid receiver

CTCY-EN – 34.1-2 / 09-2015

→ CONDOR-V (vertical)

■ Technical features

CARLY references	Drawing Nb	Dimensions mm											
		Ø1	Ø2	L1	L2	L3	L4	E1	E2	E3	E4	Ø3	Ø4
CONDOR-V 100	1	121,0	128	341	319	14	88	145	73	10	40	M10	/
CONDOR-V 150	1	121,0	128	412	390	14	88	220	73	10	40	M10	/
CONDOR-V 240	1	121,0	128	412	390	14	88	220	73	10	40	M10	/
CONDOR-V 500	2	152,4	156	535	514	17	108	330	79	15	70	M12	/
CONDOR-V 1000	2	152,4	156	645	624	23	114	430	79	15	70	M12	/
CONDOR-V 1400	3	121,0	128	472	450	23	73	288	64	10	40	M10	/
CONDOR-V 2500	4	219,1	224	553	/	23	117	290	132	15	150	3 x 10.2 x 15	200

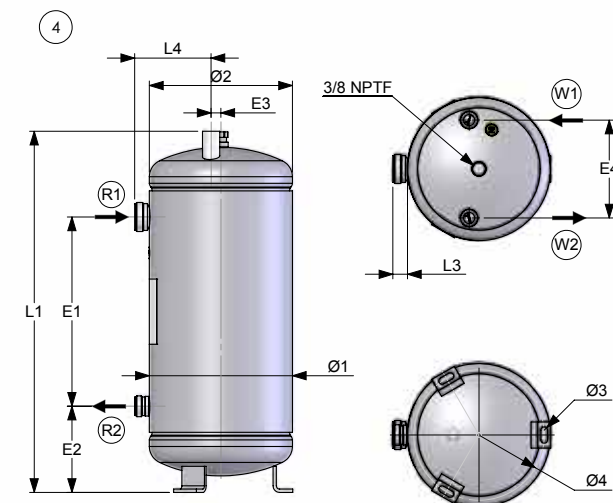
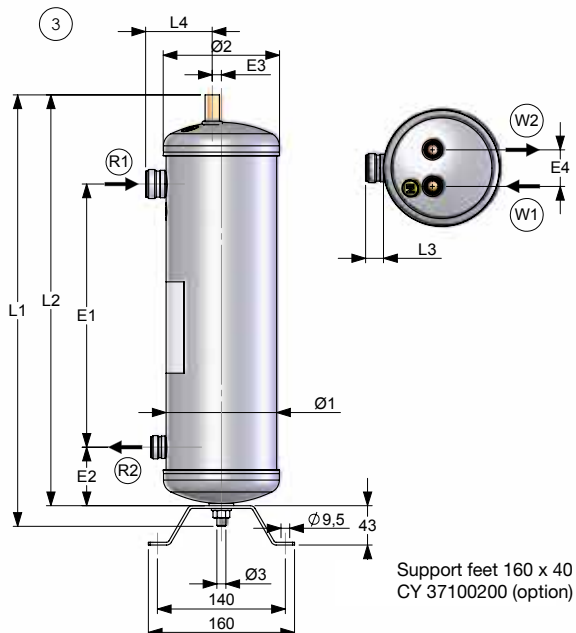
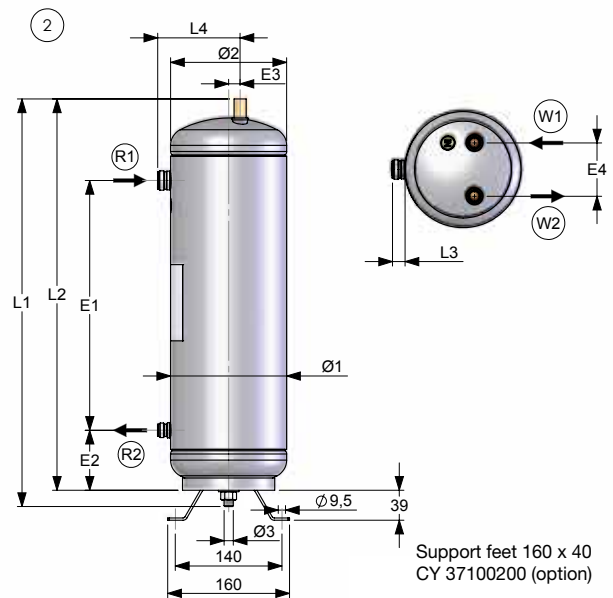
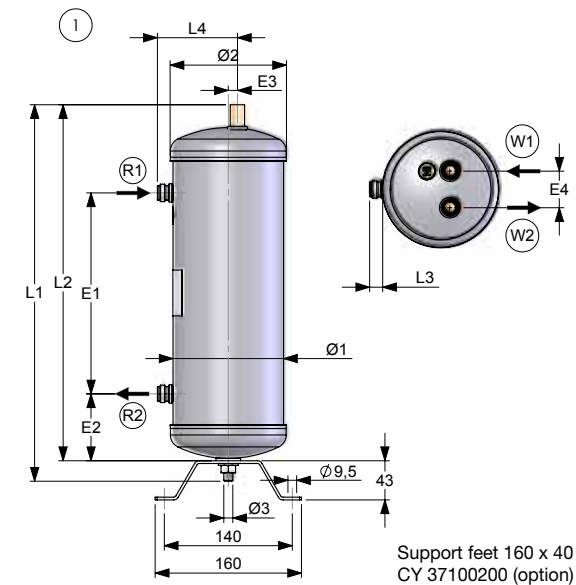



Water cooled condensers with liquid receiver

→ CONDOR-V (vertical)

■ Technical features

CARLY references	Volume	Maximal working pressure	Heat exchanger maximal working pressure	Maximal working temperature	Minimal working temperature	Working temperature	CE Category ⁽¹⁾
	V L	PS bar	PS Ech. bar	TS maxi °C	TS mini °C	TS BT °C	
CONDOR-V 100	2,6	46	10	120	-20	/	I
CONDOR-V 150	3,4	46	10	120	-20	/	I
CONDOR-V 240	3,2	46	10	120	-20	/	I
CONDOR-V 500	7,4	46	10	120	-20	/	II
CONDOR-V 1000	8,9	46	10	120	-20	/	II
CONDOR-V 1400	3,2	46	10	120	-20	/	I
CONDOR-V 2500	15,1	45	10	120	-20	/	II

⁽¹⁾ Classification by volume, according to PED 97/23/EC (refer to chapter 0).

■ Example of selection of a CONDOR water cooled condenser with liquid receiver

The sizing of a product implies for the buyer to take into account the conditions under which the product will be used (temperature - pressure - refrigerant oil external environment). The values of the selection tables proposed in the CARLY catalogue match accurate test conditions.

- Installation operating with R404A under the following conditions⁽¹⁾:
 - $Qk_x = 10 \text{ kW}$
 - $T_k = 40 \text{ °C}$
 - $T_{l1} = 20 \text{ °C} \longrightarrow \Delta t_1 = 40 - 20 = 20\text{K}$
 - Maximum water flow = 500 l/h
 - Normal city water
- Which water cooled condenser CONDOR to choose?

1° Make corrections according to the water and the refrigerantes:

- 1-1 Correction according to fouling factor F_e (refer to page 34.11)
- 1-2 Correction according to refrigerant F_r (refer to page 34.11)

Result: $Qk = Qk_x \times F_e \times F_r = 10 \text{ kW}$

2° Report the capacity to the quick selection table, page 34.11, and take note of possible condensers.

Result: CONDOR-V 500, CONDOR-V 1000, CONDOR-V 1400, CONDOR-V 2500

3° Search on the condenser feature curves, pages 34-6 to 34-9, the most suitable condenser.

- Result:
- CONDOR V-500 works with Δt_1 of 25K (page 34-13)
(does not match because $\Delta t_1 > 20\text{K}$).
 - CONDOR V-1000 matches perfectly (page 34-14).
 - CONDOR V-1400 works with a water flow of 700 l/h (page 34-14)
(does not match because water flow $> 500 \text{ l/h}$)
 - CONDOR V-2500 is too powerful because $\Delta t_1 < 20\text{K}$ (page 34-15).

4° Select the CONDOR V-1000 model and determine on the curves the water Δt and the water pressure drop (page 34-14).

Result: $\Delta t \text{ water} = 16,5\text{K}$
 $\Delta p \text{ water} = 0,25 \text{ bar}$

⁽¹⁾ Chapter «Abbreviations and units» (refer to chapter 113).



Water cooled condensers with liquid receiver

→ CONDOR-V (vertical)

■ Technical features

- According to the type of water available, the condensation capacity (Q_{kx}) of the installation should be corrected in accordance to the fouling factor by the formula:

$$Q_k = Q_{kx} \times F_e$$

Water type	Fouling factor $m^2.K / W$	Correction factor F_e
Normal city water	43.10-6	1,00
Treated tower water	43.10-6	1,00
Untreated tower water	86.10-6	1,19
River water	86.10-6	1,19
Glycol water below 40 %	86.10-6	1,19
Glycol water below 70 %	172.10-6	1,56

- According to the type of refrigerant used, the condensation capacity (Q_{kx}) of the installation should be corrected in accordance to the following F_r factor by the formula:

$$Q_k = Q_{kx} \times F_r$$

Refrigerant	Correction factor F_r
R404A / R507	1,00
R 22 / R410A / R407F	0,92
R134a / R407C	0,85

■ Quick Selection Table

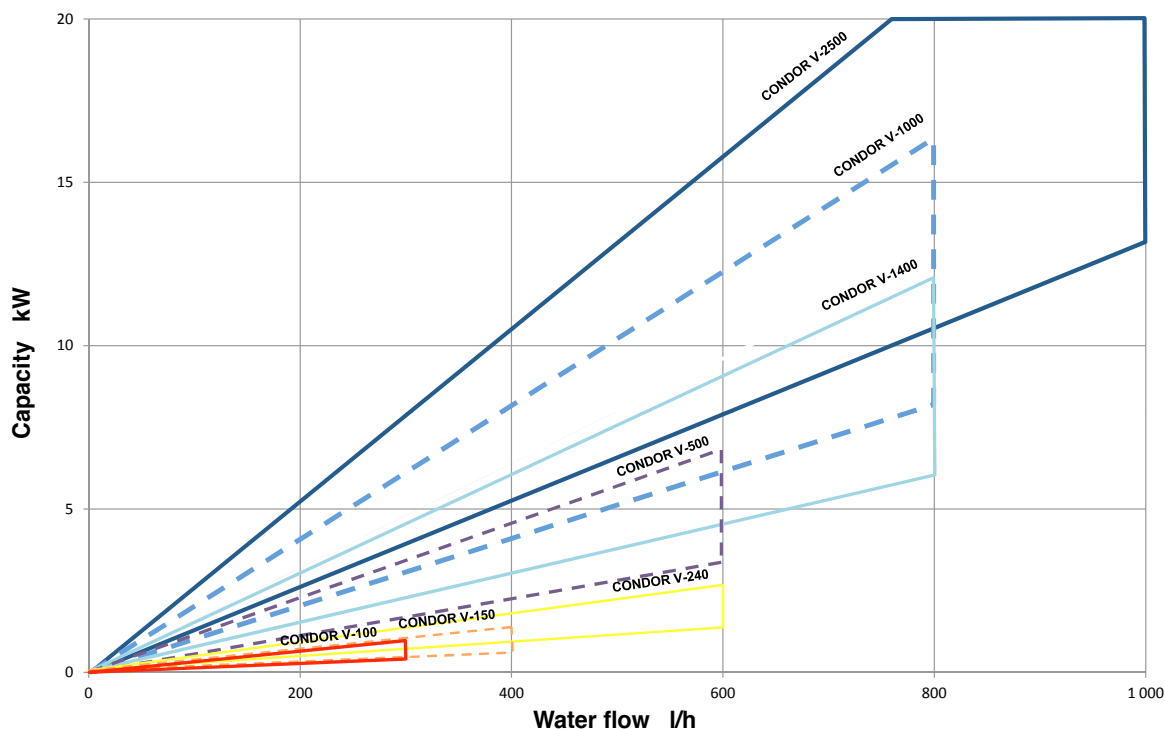



Water cooled condensers with liquid receiver

→ CONDOR-V (vertical)

■ Technical features

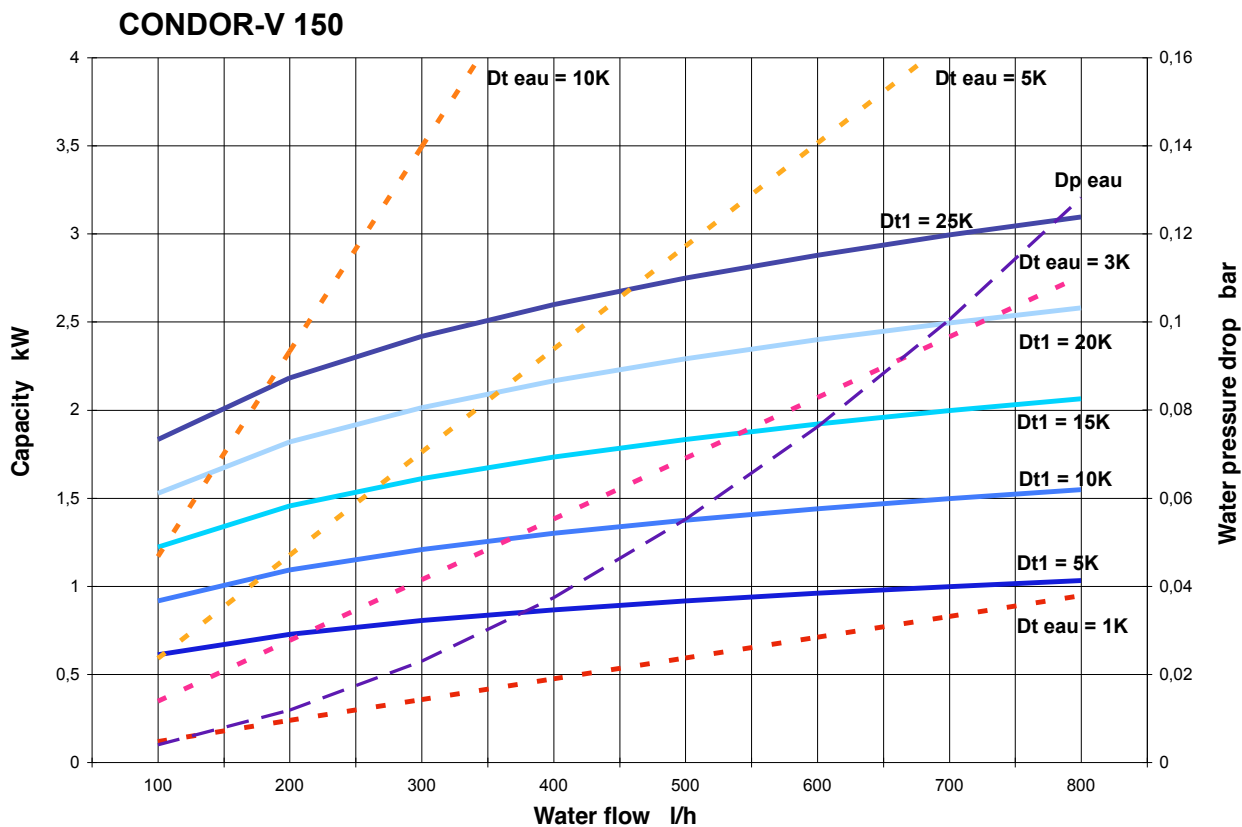
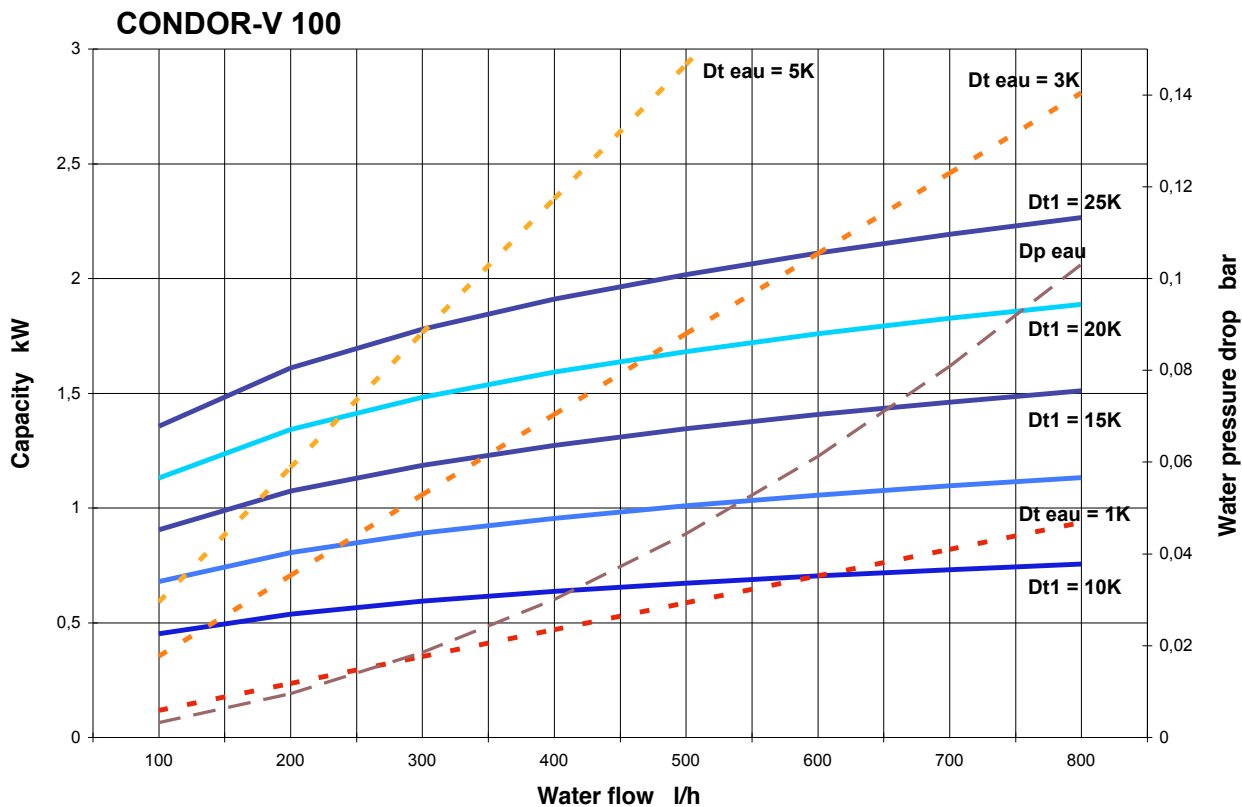



Water cooled condensers with liquid receiver

→ CONDOR-V (vertical)

■ Technical features

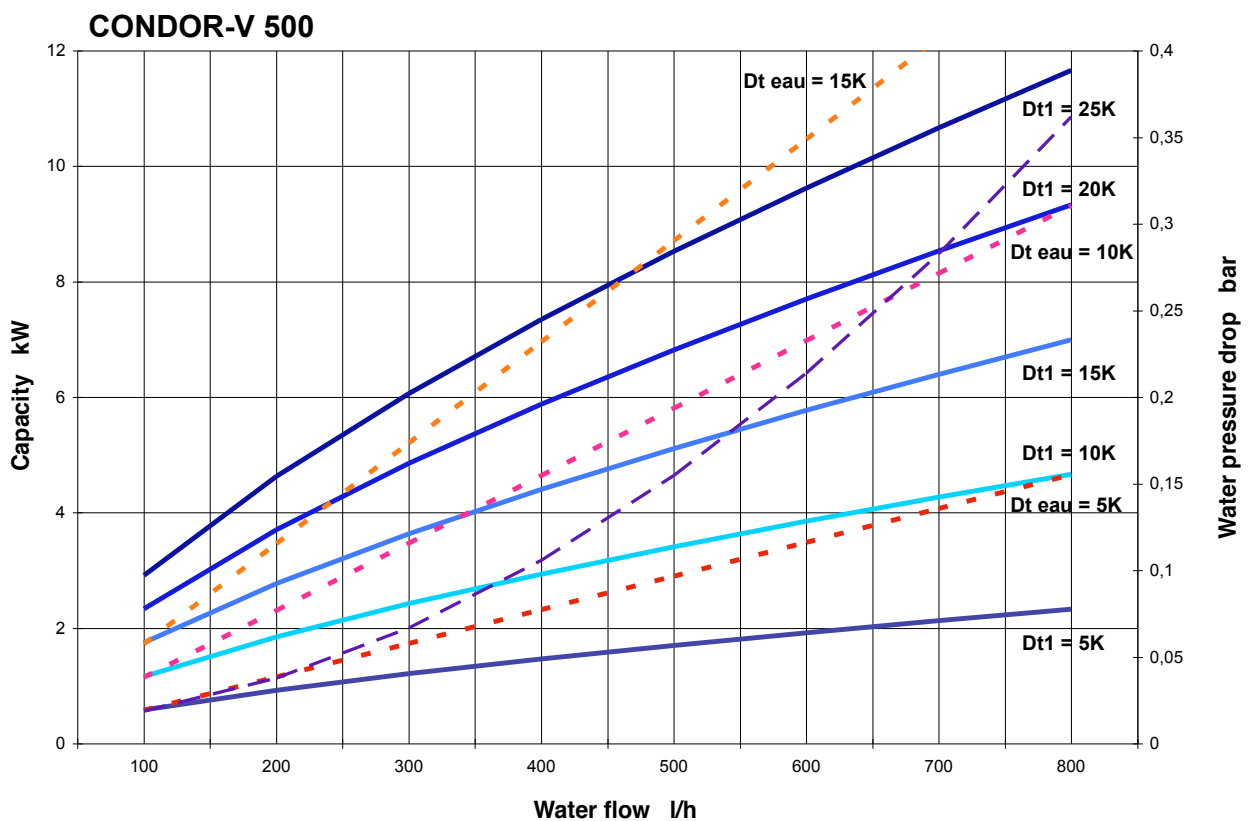
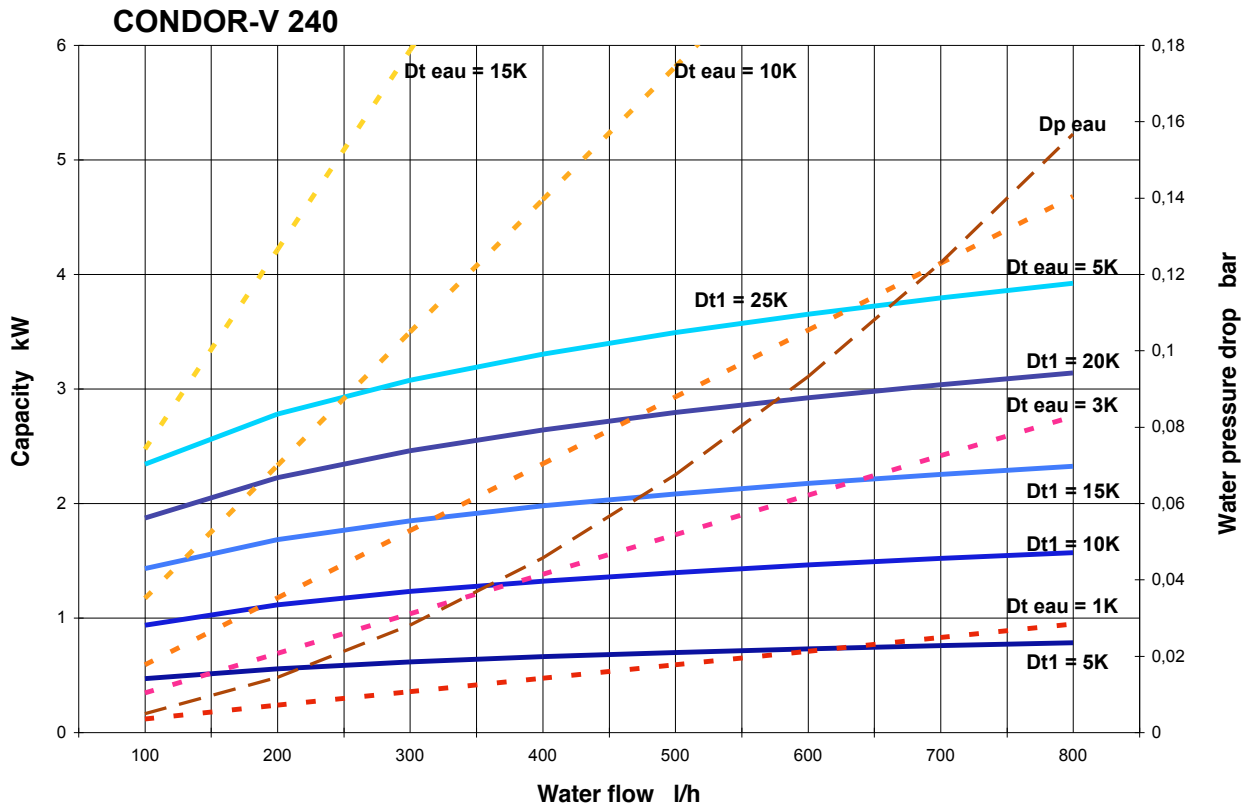



Water cooled condensers with liquid receiver

→ CONDOR-V (vertical)

■ Technical features

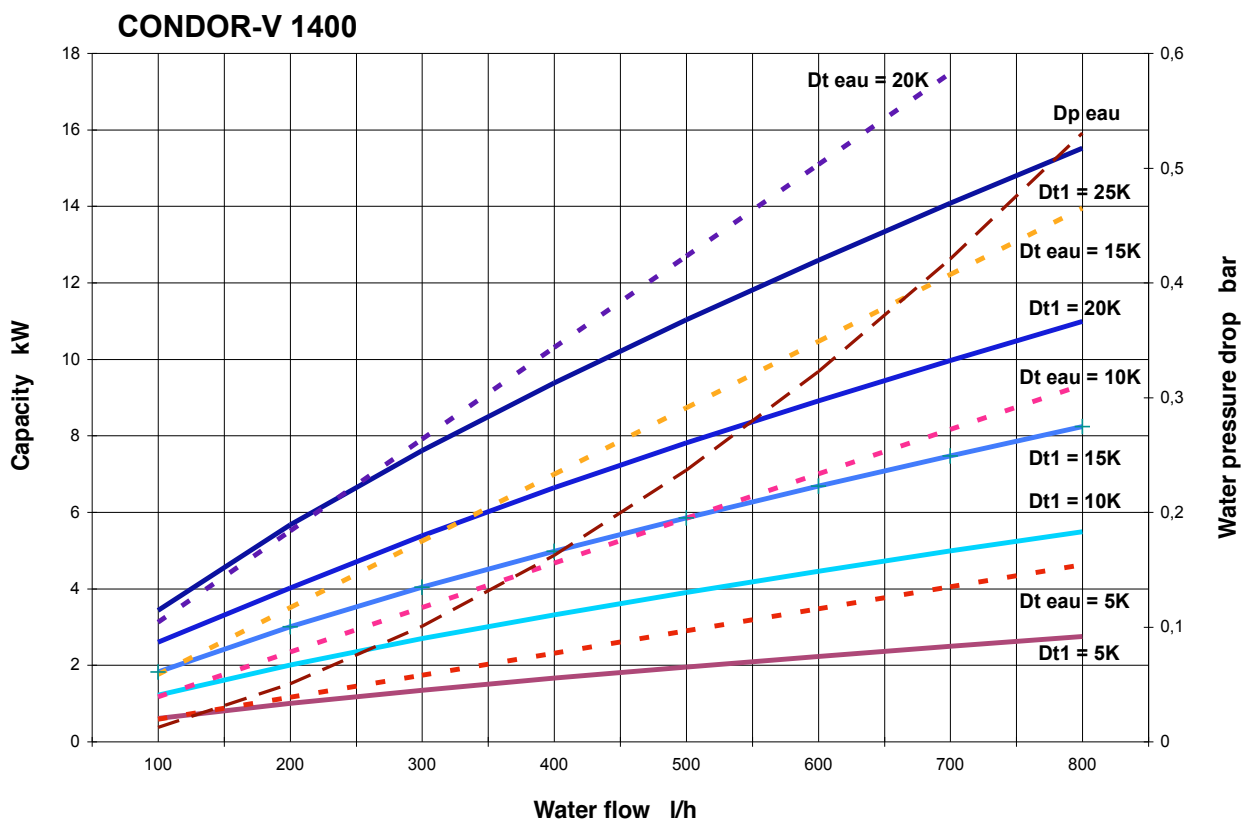
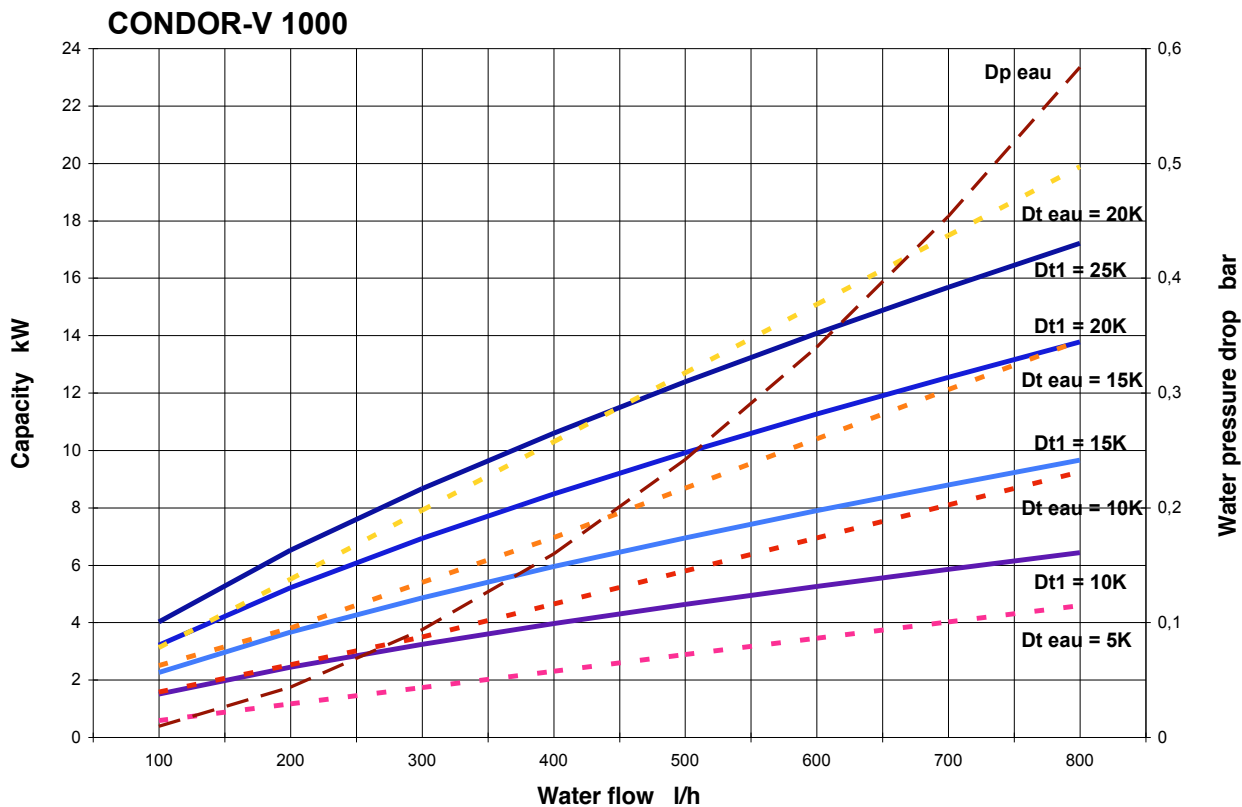



Water cooled condensers with liquid receiver

CTCY-EN – 34.1-2 / 09-2015

→ CONDOR-V (vertical)

■ Technical features

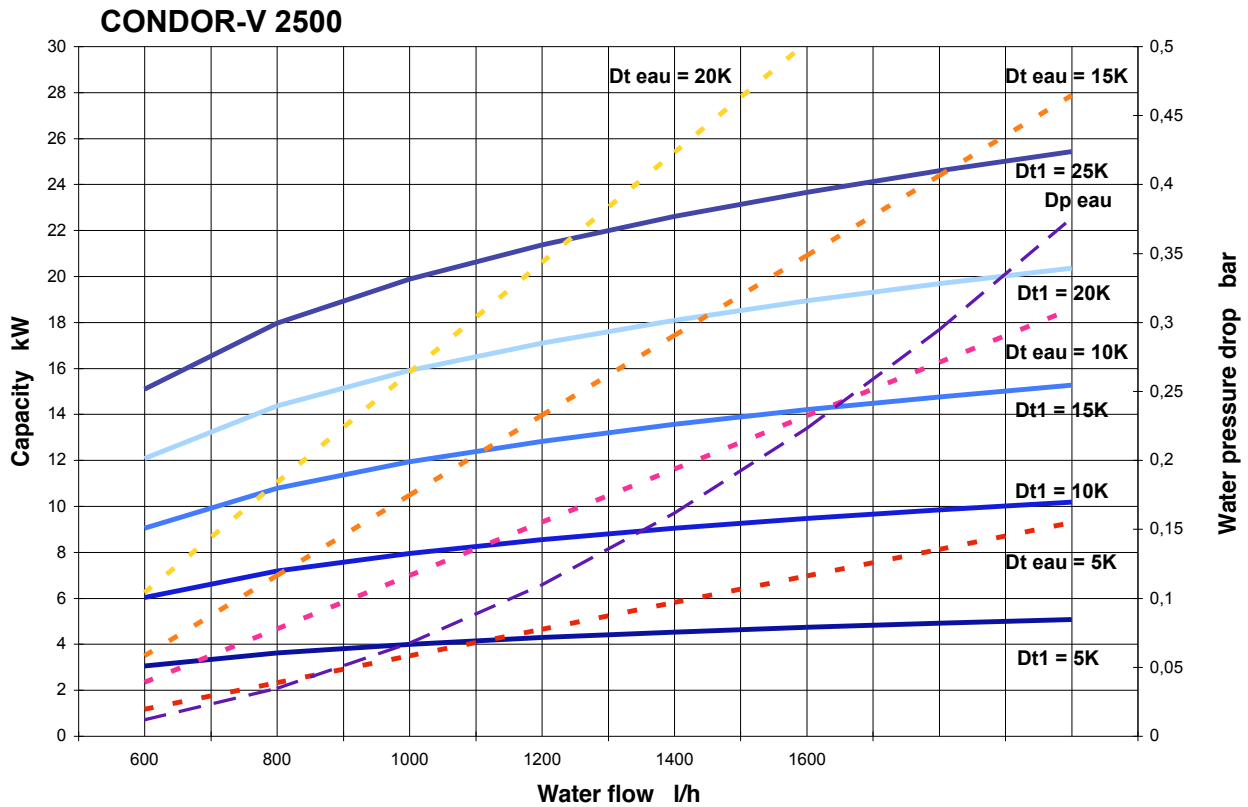



Water cooled condensers with liquid receiver

→ CONDOR-V (vertical)

■ Spare parts and options

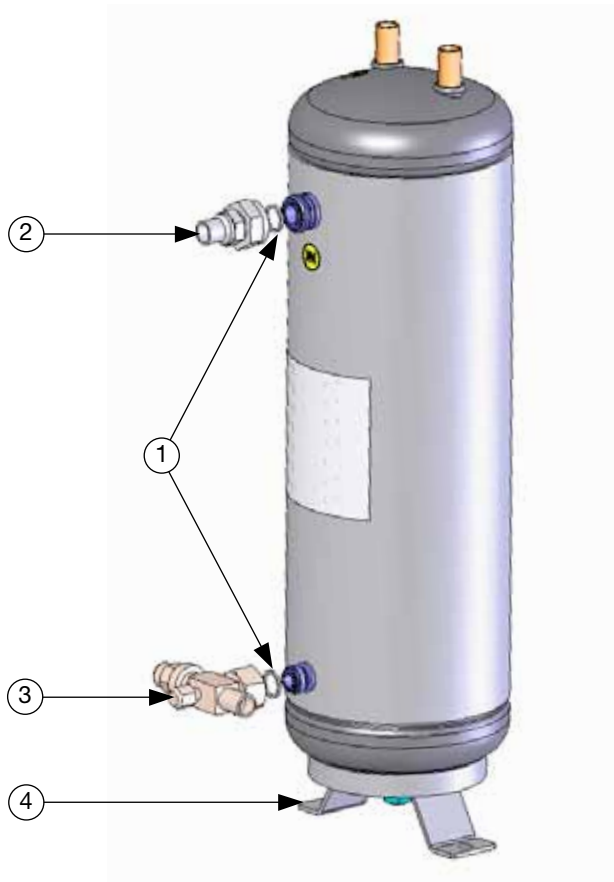

CONDOR V ⁽¹⁾	CARLY references	Part N°	Gasket for ROTALOCK connections and valves inch
100 - 150 - 240 - 500(S)	CY 15580100	1	1/4, 3/8
1000(E)-1400(E)-2500(S)	CY 15580120	1	5/8, 7/8, 1 1/8
500(E)-1000 (S)-1400(S)	CY 15580140	1	1/2

⁽¹⁾ (E) = Inlet, (S) = Outlet

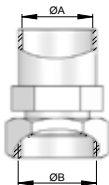

CONDOR V ⁽¹⁾	CARLY references	Part N°	ROTALOCK connections, gasket included	
			ØA outlet ODF connection inch	ØB fixing UNF connector inch
100 - 150 - 240 - 500(S)	CY 17400000	2	1/4	3/4
100 - 150 - 240 - 500(S)	CY 17400010	2	3/8	3/4
500(E)-1000(S)-1400(S)	CY 17400020	2	1/2	1
1000(E)-1400(E)-2500(S)	CY 17400035	2	5/8	1 1/4
1000(E)-1400(E)-2500(S)	CY 17400040	2	7/8	1 1/4
1000(E)-1400(E)-2500(S)	CY 17400050	2	1 1/8	1 1/4

⁽¹⁾ (E) = Inlet, (S) = Outlet



Water cooled condensers with liquid receiver

→ CONDOR-V (vertical)

■ Spare parts and options

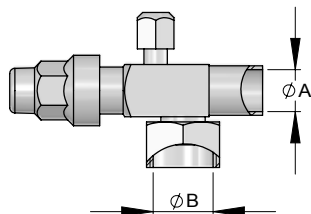

CONDOR V ⁽¹⁾	CARLY references	Part N°	ROTALOCK valve with connection to solder, gasket included	
			ØA outlet ODF valve inch	ØB fixing UNF valve inch
100 - 150 - 240 - 500(S)	CY 19700080	3	1/4	3/4
100 - 150 - 240 - 500(S)	CY 19700110	3	3/8	3/4
500(E)-1000(S)-1400(S)	CY 19700120	3	1/2	1
500(E)-1000(S)-1400(S)	CY 19700130	3	5/8	1
1000(E)-1400(E)-2500(S)	CY 19700135	3	5/8	1 1/4
1000(E)-1400(E)-2500(S)	CY 19700160	3	7/8	1 1/4
1000(E)-1400(E)-2500(S)	CY 19700170	3	1 1/8	1 1/4

⁽¹⁾ (E) = Inlet, (S) = Outlet

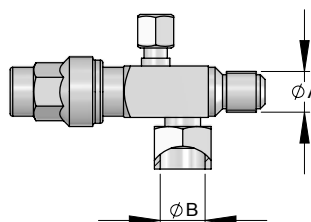

CONDOR V ⁽¹⁾	CARLY references	Part N°	ROTALOCK valve with connection to screw, gasket included	
			ØB fixing SAE valve inch	ØB fixing UNF valve inch
100 - 150 - 240 - 500(S)	CY 19700090	3	1/4	3/4
100 - 150 - 240 - 500(S)	CY 19700100	3	3/8	3/4
500(E)-1000(S)-1400(S)	CY 19700140	3	1/2	1

⁽¹⁾ (E) = Inlet, (S) = Outlet

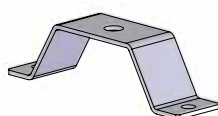

CONDOR V	CARLY references	Part N°	Description
100 - 150 - 240 - 500 - 1000 - 1400	CY 37100200	4	Support feet

■ Weights and packaging

CARLY references	Unit weight kg		Packaging number of pieces
	With packaging	Without packaging	
CONDOR-V 100	4,50	4,20	1
CONDOR-V 150	5,65	5,20	1
CONDOR-V 240	5,65	5,20	1
CONDOR-V 500	11,10	10,80	1

CARLY references	Unit weight kg		Packaging number of pieces
	With packaging	Without packaging	
CONDOR-V 1000	14,30	14,00	1
CONDOR-V 1400	7,65	7,20	1
CONDOR-V 2500	26,10	25,50	1