





Manual systems for sliding doors up to 80 and 120 kg maximum



 **Ref. 2320** : System for doors of a maximum door weight of 80 kg, minimum door thickness of 50 mm

 **Ref. 2420** : System for doors of a maximum door weight of 120 kg, minimum door thickness of 50 mm

Features and advantages :

- Pleasing appearance and excellent hygiene properties are achieved by the 15 microns anodised aluminium rail concealing the mechanical components
- Smooth & silent operation achieved by the composite rollers being supported by a bearing bracket
- Safety is maximised through use of an anti-derailment feature
- Compact size through design
- The special gasket remains soft down to - 40 degrees C
- Products in accordance to the European Directives and Standards

ACCESSORIES

- Internal and external lever handles, face or edge-fixing
- Internal and external fixed handles
- Gaskets

OPTIONS

- Lock 57 / 57 HP
- Bottom guide rail fixed on the underside of the door
- Frame guiding system
- Automatic system *

* Ask for detailed literature





FERMATIC 2320 - 2420

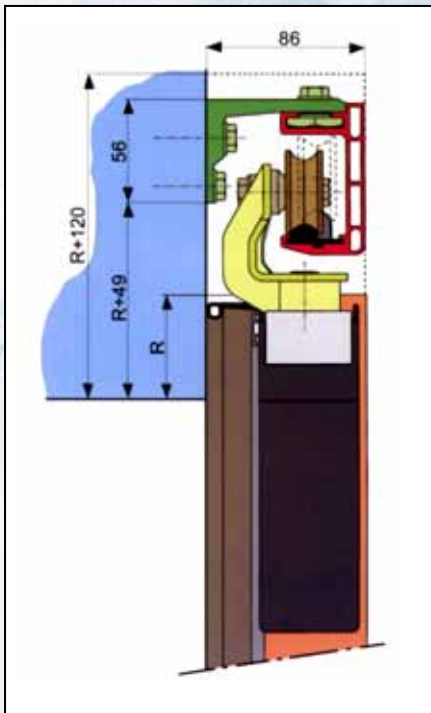
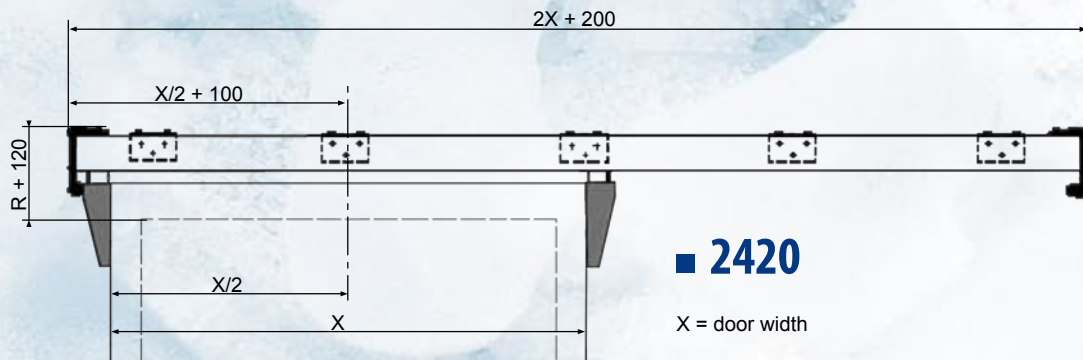
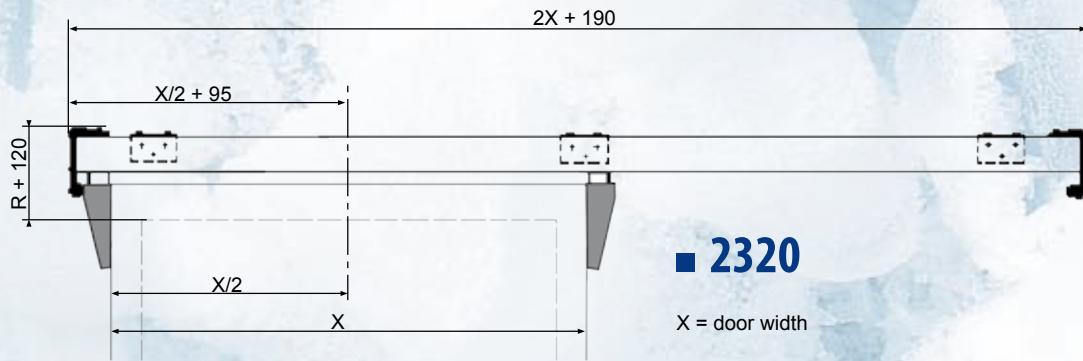

References	Door width
2321 / 2421	900 to 1100 mm
2322 / 2422	1101 to 1300 mm
2323 / 2423	1301 to 1500 mm
2324 / 2424	1501 to 1700 mm
2325 / 2425	1701 to 2000 mm
2326 / 2426	2001 to 2300 mm
2327 / 2427	2301 to 2600 mm

. Delivered also in 6180 mm length

DISTRIBUTOR

Imp. POLYSERVICES - Beauvais



FERMOD®



75, rue de Richelieu - 75002 PARIS - FRANCE
Tél. : 33 (0)1 42 96 94 06 - Fax : 33 (0)1 42 86 84 51
<http://www.fermod.com> • e-mail: contact@fermod.com

Siège Social : Senlis (Oise) - Société Anonyme au Capital de 1 004 400 €
RCS Senlis B 301 468 211 - Siret 301 468 211 00018 - APE 2572 Z

