

**MINI CREAM 2V LED R600  
(COD. E1939S0100)**



display

Technical data

<b>Working temperature</b>	-10°C-22°C
<b>Voltage and Frequency</b>	230 V~ 50 Hz
<b>Gas</b>	R600a
<b>Net dimension</b>	490 x 790 x 345 mm (l x p x h)
<b>Packed dimension</b>	590 x 890 x 375 mm (l x p x h)
<b>Gross capacity</b>	28 l
<b>Net capacity</b>	20 l
<b>Gross weight</b>	32.00 Kg
<b>Net weight</b>	28.00 Kg
<b>Heat insulation</b>	Rigid polyurethane foam "HCFC/CFC/HFC" free
<b>External cabinet</b>	White prepainted steel sheet
<b>Cabinet bottom</b>	Galvanized steel sheet
<b>Inner tank</b>	Stainless steel - AISI 304 BA
<b>Light tank</b>	Internal light LED
<b>Frame</b>	White thermoformed plastic
<b>Top</b>	Low emissivity glass
<b>Back grid - colour</b>	White plasticised steel rod
<b>Compressor</b>	1/6 HP
<b>absorbed power</b>	95 W
<b>Power consumption (24h)</b>	1,8 kWh/24h
<b>Condensator</b>	Wire and tube - maintenance free with powered fan
<b>Evaporator</b>	Static evaporator wrapping the tank
<b>Defrosting</b>	Manual
<b>Climatic class - EN 441</b>	4 (30°C-55%RH) L1
<b>Plug</b>	European - Angular Plug
<b>Thermometer</b>	Mechanical
<b>Thermostat</b>	Mechanical
<b>Standard equipment</b>	Basket for stainless steel bins 5-2,5 lt
<b>Optional</b>	Stainless steel bins
<b>Brand</b>	MONDIAL ELITE
<b>Producer brand</b>	MONDIAL GROUP

MINI CREAM 2V LED R600  
(COD. E1939S0100)



display

Layout

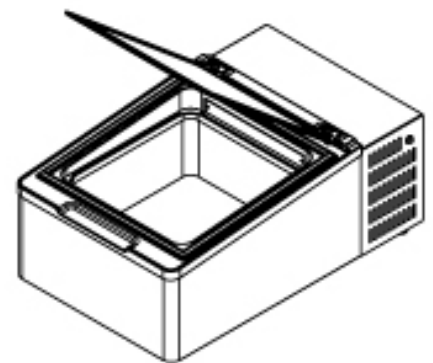
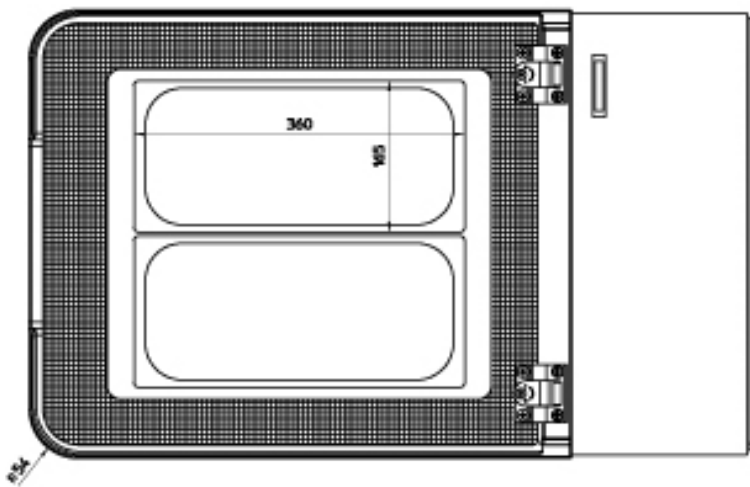
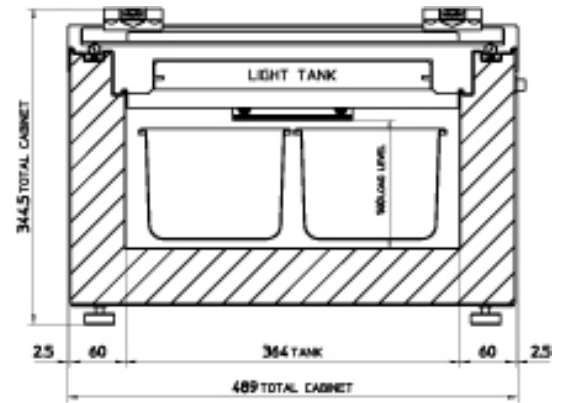
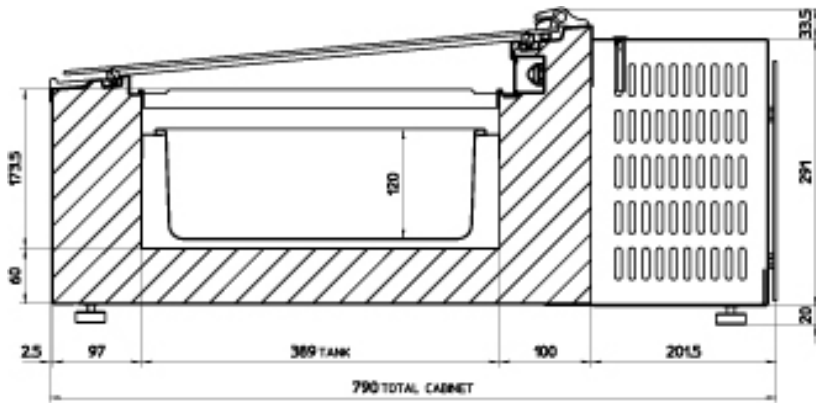

ICE 2V GLASS LED  
S\_46233 REV. 00

**MINI CREAM 2V LED R600  
(COD. E1939S0100)**



display

Image



Updated on
05/11/2015