

Unit coolers MUC-LUC



New design: MUC-LUC (fan guard \varnothing 300 mm)

MUC-LUC cubic unit coolers are suitable for chilling or low temperature storage applications. 48 basic models with capacities ranging from 1 to 13,7 kW.



FRIGA-BOHN



Unit coolers

MUC-LUC



Description

Casing

- Robust and attractive casing made of white enamelled steel, which enables easy cleaning of the unit.

Drain pan

- Drain pan with rounded corners eliminating retention zones in which pathogenic germs may develop and guaranteeing total safety by the absence of sharp edges and corners.

Ventilation

- MUC-LUC range is fitted with life lubricated, propeller motorfans, factory wired:
 - **Ø 300 mm (new design)**: standard type, 230 V/1/ 50-60 Hz, enclosed frame motor, class B, overload protector included. **New design**: fan guards are in conformity with safety regulations, fitted with air stream straighteners thus ensuring a long air throw.
 - **Ø 400 and 450 mm**: standard type, 230-400 V/3/ 50-60 Hz, enclosed frame motor with drain holes, IP54, class F, including overload protector for field wiring. Fans Ø 450 mm fitted with plastic guards, fans Ø 400 mm fitted with plastic coated steel wire guards.
- Guard design conform to safety regulations.

Coil

- The highly efficient and compact MUC-LUC range finned coils are designed with corrugated surface aluminium fins (fin spacing 4.23 or 6.35 mm) and grooved internal structure copper tubes.
- The refrigerant distributors are nozzle type (nozzle factory fitted).

Defrost

- Tubular electric heaters are inserted in slots both on the front and rear coil faces. No lateral space is required for heater removing, except for MUC-R and MUC-L. equipped of kit E1K.
- One of these heaters is located in the drain pan.
- Heaters are wired in our works, to a terminal block located in a sealed junction box :
 - LUC 155 E, 210 E, 295 E and 150 C, 205 C models are factory coupled for 230 V/1 supply.
 - LUC 350 E to 1030 E and 290 C to 1025 C models are factory coupled for 230-400 V/3 supply.
- Defrost water is collected in the drain pan then drained through a large drain fitting (Ø 1" G).

Accessibility

- Side panels and drain pan easily removed, facilitating a full access to all unit components (coil, motorfans, defrost heaters, connections...).

Nomenclature

MUC₍₁₎ 320₍₂₎ R₍₃₎

- (1) Unit cooler
(2) Model
(3) Fins spacing : R/E = 4,23 mm - L/C = 6,35 mm

Options

Ventilation

- M60** Special fans for 60 Hz application.
MM5 Single phase 230 V 50 Hz fan assembly.

Coil

- BAE** Coating of the fins.
WCO Glycol water, brine (please consult us).
CO2 R744 optimization (please consult us).

Defrost

- 2TH** **TH 5709L** : defrost termination and fan delay thermostat with single-pole, reversing switch at +12 °C (±3 °C) and +2 °C (±3 °C).
THS 5708L : single-pole thermostat for overheating safety at +24 °C (±3°C). Recommended with electric defrost.
- HG1** Hot gas (**LUC**) (coil: hot gas, drain pan: electrical heaters).
ECK Additional electrical defrosting kit (drain pan) (**LUC**)
ECU Additional electrical defrosting (drain pan) (**LUC**)
E1K Electrical defrost kit (**MUC**): heaters located in sleeves (required lateral space for fitting).
E1U Light electrical defrost.

Fully equipped unit coolers

- EEC** Fully equipped unit cooler (see pages "APPENDIX").

Other options

Please consult us.



EUROVENT - The performance published of our products are certified in conformity with european standards EN327, EN328, EN1048.



ISO 9001 - Our company is certified by LRQA to comply with quality standards ISO 9001.



RoHS - WEEE - Our products are compliant with regards to european guideline 2002/95/CE and 2002/96/CE concerning electric and enlectronic components.



CE - Our products are in conformity with european guidelines.



GOST - Products in conformity with "GOST" agreement.

"According the requirements of the European measures, we draw your attention to the fact that our technical documents are at least translated into french and english. For any translation in another language such as the end user can require it, thank you to consult us."

MUC ... R

4,23 mm

		MUC ... R	145	200	285	320	420	520	620	640	660	670	780	960	
Capacity	DT1 = 8 K - SC2 (1)	kW	1,44	2,31	3,48	3,83	4,94	5,89	7,17	8,23	9,56	10,89	12,01	13,67	
Surface		m ²	5,5	8,7	10	13,4	18,2	21,4	25,8	40,2	48,7	48,7	32,3	38,6	
Circuit volume		dm ³	1,1	1,8	1,9	2,6	3,5	4,0	4,8	6,9	8,3	8,3	6,0	7,2	
Air flow		m ³ /h	1246	1239	2336	2076	2562	3252	3696	3264	3486	4168	7095	7895	
Fan	Air throw (2)	m	12	12	12	12	12	12	12	12	12	12	28	45	
	Num. x Ø	mm	1 x 300	1 x 300	2 x 300	2 x 300	2 x 300	3 x 300	3 x 300	3 x 300	3 x 300	4 x 300	2 x 400	2 x 450	
	50-60 Hz 1500 r.p.m.	230 V/1/50 Hz	W Total	145	145	290	290	290	435	435	435	435	580	-	-
		A Total	0,85	0,85	1,70	1,70	1,70	2,55	2,55	2,55	2,55	3,40	-	-	
400 V/3/50 Hz	W max	-	-	-	-	-	-	-	-	-	-	-	2 x 360	2 x 360	
	A max (3)	-	-	-	-	-	-	-	-	-	-	-	2 x 1,0	2 x 1,0	
Electric defrost E1K (4)		Num.	3	3	3	3	3	3	3	3	3	3	3	3/6	
		W Total	420	630	780	960	1320	1560	1860	2550	3150	3150	2340	1740/3480	
	230 V/1/50 Hz	A Total	1,8	2,8	3,4	4,2	5,8	6,8	8,1	-	-	-	-	-	
	400 V/3/50 Hz	A Total	-	-	-	-	-	-	-	3,7	4,6	4,6	3,4	2,5/5,0	
Net weight		kg	16	18	22	27	32	43	44	56	68	70	63	73	
	A	mm	575	575	981	981	1235	1355	1665	1998	2348	2348	1657	1657	
	B	mm	400	464	400	400	400	464	400	400	400	400	495	590	
	C	mm	365	365	365	365	365	365	365	365	365	365	482	482	
	D	mm	355	419	355	355	355	419	352	350	350	350	447	538	
	E	mm	42	39	89	89	89	89	110	110	110	110	110	110	
	H	mm	53	53	53	53	53	53	53	53	53	53	68	78	
	K	mm	456	456	456	456	456	456	456	456	456	456	596	606	
	R	mm	72	72	122	122	122	182	147	147	147	147	147	147	
	X	mm	416	416	722	722	976	976	1356	1686	2036	2036	1356	1356	
Y	mm	412	412	412	412	412	412	412	412	412	412	536	536		
Inlet		Ø (5)	D 1/2"	D 1/2"	D 1/2"	D 1/2"	D 1/2"	D 1/2"	D 1/2"	D 1/2"	D 7/8"	D 7/8"	D 7/8"	D 1 1/8"	
Outlet		Ø ODF (6)	1/2"	1/2"	5/8"	5/8"	3/4"	3/4"	7/8"	7/8"	7/8"	7/8"	1 1/8"	1 3/8"	

(1) See pages "APPENDIX".

(2) Residual air velocity: 0.25 m/s, in accordance with norm.

(3) Setting of overload protections. For room temperatures 'ti' other than +20 °C, multiply the given amperage by the ratio 293/(273 + 'ti') so as to obtain the approximate amperage after the room pull down.

(4) Electric defrost option.

(5) Liquid distributor: male to be brazed.

(6) ODF: female sweat type connection.

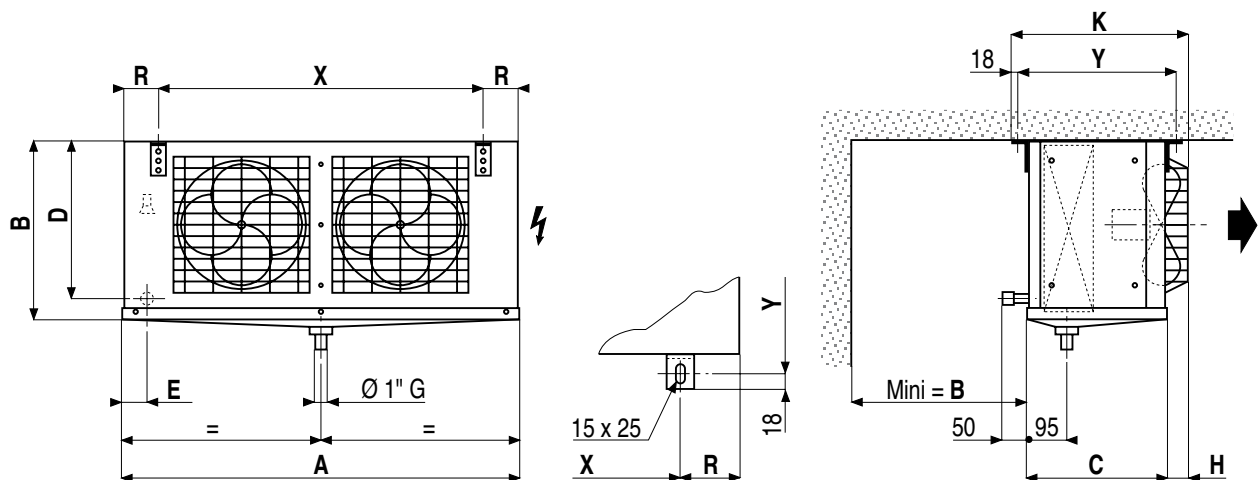

	BAE	WCO	CO2	2TH	HG1	ECK	ECU	E1K	E1U	M60*	MM5*	EEC
MUC ... R	0	-	-	0	-	-	-	0	0	0	0	0

* Only three-phase motors

MUC ... L

6,35 mm

		MUC ... L	140	195	280	315	415	515	615	635	655	665	775	955	
Capacity	DT1 = 8 K - SC2 (1)	kW	1,70	2,07	3,17	3,46	4,52	5,49	6,42	6,89	7,41	9,00	10,61	12,20	
Glycol water*	DT1 = 8 K - SC2 (1)	kW	1,62	-	3,33	-	4,53	-	6,88	-	-	8,38	-	-	
Surface		m ²	5,17	7,54	9,33	11,66	15,98	18,64	22,43	27,80	33,70	33,70	28,04	33,65	
Circuit volume		dm ³	1,5	2,3	2,5	3,3	4,4	5,0	6,0	6,9	8,4	8,4	7,5	9,0	
Air flow		m ³ /h	1217	1239	2267	2075	2561	3250	3694	3435	3624	4436	7093	7893	
	Air throw (2)	m	12	12	12	12	12	12	12	12	12	12	28	45	
	Num. x Ø	mm	1 x 300	1 x 300	2 x 300	2 x 300	2 x 300	3 x 300	3 x 300	3 x 300	3 x 300	4 x 300	2 x 400	2 x 450	
Fan 50-60 Hz 1500 r.p.m.	230 V/1/50 Hz	W Total	145	145	290	290	290	435	435	435	435	580	-	-	
		A Total	0,85	0,85	1,70	1,70	1,70	2,55	2,55	2,55	2,55	3,40	-	-	
	400 V/3/50 Hz	W max	-	-	-	-	-	-	-	-	-	-	2 x 360	2 x 360	
		A max (3)	-	-	-	-	-	-	-	-	-	-	2 x 1,0	2 x 1,0	
Electric defrost E1K (4)	230 V/1/50 Hz	Num.	3	3	3	3	3	3	3	3	3	3	3	3/6	
		W Total	420	630	780	960	1320	1560	1860	2550	3150	3150	2340	1740/3480	
	400 V/3/50 Hz	A Total	1,8	2,8	3,4	4,2	5,8	6,8	8,1	-	-	-	-	-	
		A Total	-	-	-	-	-	-	-	3,7	4,6	4,6	3,4	2,5/5,0	
Net weight		kg	16	18	22	27	32	43	44	56	68	70	63	73	
Dimensions	A	mm	575	575	981	981	1235	1355	1665	1998	2348	2348	1657	1657	
	B	mm	400	464	400	400	400	464	400	400	400	400	495	590	
	C	mm	365	365	365	365	365	365	365	365	365	365	482	482	
	D	mm	355	419	355	355	355	419	352	350	350	350	447	543	
	E	mm	42	39	89	89	89	89	110	110	110	110	110	110	
	H	mm	53	53	53	53	53	53	53	53	53	53	68	78	
	K	mm	456	456	456	456	456	456	456	456	456	456	456	596	606
	R	mm	72	72	122	122	122	182	147	147	147	147	147	147	
	X	mm	416	416	722	722	976	976	1356	1686	2036	2036	1356	1356	
	Y	mm	412	412	412	412	412	412	412	412	412	412	536	536	
Inlet	Ø (5)	D 1/2"	D 1/2"	D 1/2"	D 1/2"	D 1/2"	D 1/2"	D 1/2"	D 1/2"	D 7/8"	D 7/8"	D 7/8"	D 1 1/8"	D 1 1/8"	
Outlet	Ø ODF (6)	1/2"	1/2"	5/8"	5/8"	3/4"	3/4"	7/8"	7/8"	7/8"	7/8"	1 1/8"	1 1/8"		

(1) See pages "APPENDIX".

(2) Residual air velocity: 0.25 m/s, in accordance with norm.

(3) Setting of overload protections. For room temperatures 't_i' other than +20 °C, multiply the given amperage by the ratio 293/(273 + 't_i') so as to obtain the approximate amperage after the room pull down.

(4) Electric defrost option.

(5) Liquid distributor: male to be brazed.

(6) ODF: female sweat type connection.

* Glycol water:

Fluid : Percentage of glycol = 30 % - Fluid inlet temperature = - 8 °C - Fluid outlet temperature = - 4 °C

Air Dry airinlet temperature = + 2 °C - Relative humidity = 85 % - Other conditions: please consult us.

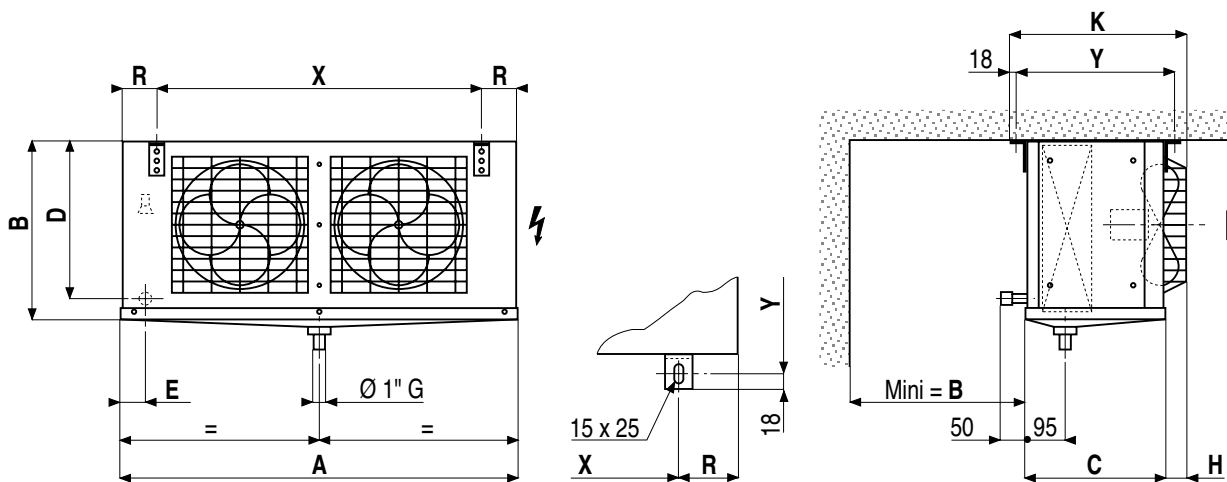

	BAE	WCO	CO2	2TH	HG1	ECK	ECU	E1K	E1U	M60*	MM5*	EEC
MUC ... L	0	+	-	0	-	-	-	0	0	0	0	0

* Only three-phase motors

LUC ... E

4,23 mm

		LUC ... E	155	210	295	350	440	550	650	700	710	720	840	1030	
Capacity	DT1 = 7 K - SC3 (1)	kW	1,42	1,84	2,69	3,03	3,96	4,86	5,68	6,92	7,51	8,47	9,24	10,60	
	DT1 = 6 K - SC4 (1)	kW	1,10	1,44	2,04	2,37	3,12	3,82	4,48	5,73	6,22	6,94	7,26	8,35	
Surface		m ²	5,5	8,7	10	13,4	18,2	21,4	25,8	40,2	48,7	48,7	32,3	38,6	
Circuit volume		dm ³	1,1	1,8	1,9	2,6	3,5	4,0	4,8	6,9	8,4	8,4	6,0	7,2	
Air flow		m ³ /h	1246	1239	2336	2076	2562	3252	3696	3264	3486	4168	7095	7895	
Fan	Air throw (2)	m	12	12	12	12	12	12	12	12	12	12	28	45	
	Num. x Ø	mm	1 x 300	1 x 300	2 x 300	2 x 300	2 x 300	3 x 300	3 x 300	3 x 300	3 x 300	4 x 300	2 x 400	2 x 450	
	50-60 Hz	230 V/1/50 Hz	W Total	145	145	290	290	290	435	435	435	435	580	-	-
			A Total	0,85	0,85	1,70	1,70	1,70	2,55	2,55	2,55	2,55	3,40	-	-
	1500 r.p.m.	400 V/3/50 Hz	W max	-	-	-	-	-	-	-	-	-	-	2 x 360	2 x 360
			A max (3)	-	-	-	-	-	-	-	-	-	-	2 x 1,0	2 x 1,0
Electric defrost	Coil	Num.	1	2	3	5	5	5	5	5	5	5	5	8	
	Drain pan	Num.	1	1	1	1	1	1	1	1	1	1	1	1	
		W Total	1300	2150	2000	3000	3600	3600	5640	6900	8400	8400	5640	8460	
	230 V/1/50 Hz	A Total	5,7	9,4	8,7	-	-	-	-	-	-	-	-	-	
	400 V/3/50 Hz	A Total	-	-	-	4,4	5,2	5,2	8,2	9,9	12,1	12,1	8,2	12,2	
Dimensions	Net weight	kg	16	18	22	27	32	43	44	57	69	71	63	73	
	A	mm	575	575	981	981	1235	1355	1665	1998	2348	2348	1657	1657	
	B	mm	400	464	400	400	400	464	400	400	400	400	495	590	
	C	mm	365	365	365	365	365	365	365	365	365	365	482	482	
	D	mm	355	419	355	355	355	419	342	340	340	340	442	538	
	E	mm	42	39	89	89	89	89	110	110	110	110	110	110	
	H	mm	53	53	53	53	53	53	53	53	53	53	68	78	
	K	mm	456	456	456	456	456	456	456	456	456	456	596	606	
	R	mm	72	72	122	122	122	182	147	147	147	147	147	147	
	X	mm	416	416	722	722	976	976	1356	1686	2036	2036	1356	1356	
	Y	mm	412	412	412	412	412	412	412	412	412	412	536	536	
	Inlet	Ø (5)	D 1/2"	D 1/2"	D 1/2"	D 1/2"	D 1/2"	D 1/2"	D 1/2"	D 1/2"	D 7/8"	D 7/8"	D 7/8"	D 1 1/8"	D 1 1/8"
Outlet	Ø ODF (6)	1/2"	5/8"	3/4"	3/4"	7/8"	7/8"	1 1/8"	1 1/8"	1 1/8"	1 1/8"	1 1/8"	1 3/8"	1 3/8"	

(1) See pages "APPENDIX".

(2) Residual air velocity: 0.25 m/s, in accordance with norm.

(3) Setting of overload protections. For room temperatures 'ti' other than +20 °C, multiply the given amperage by the ratio 293/(273 + 'ti') so as to obtain the approximate amperage after the room pull down.

(5) Liquid distributor: male to be brazed.

(6) ODF: female sweat type connection.

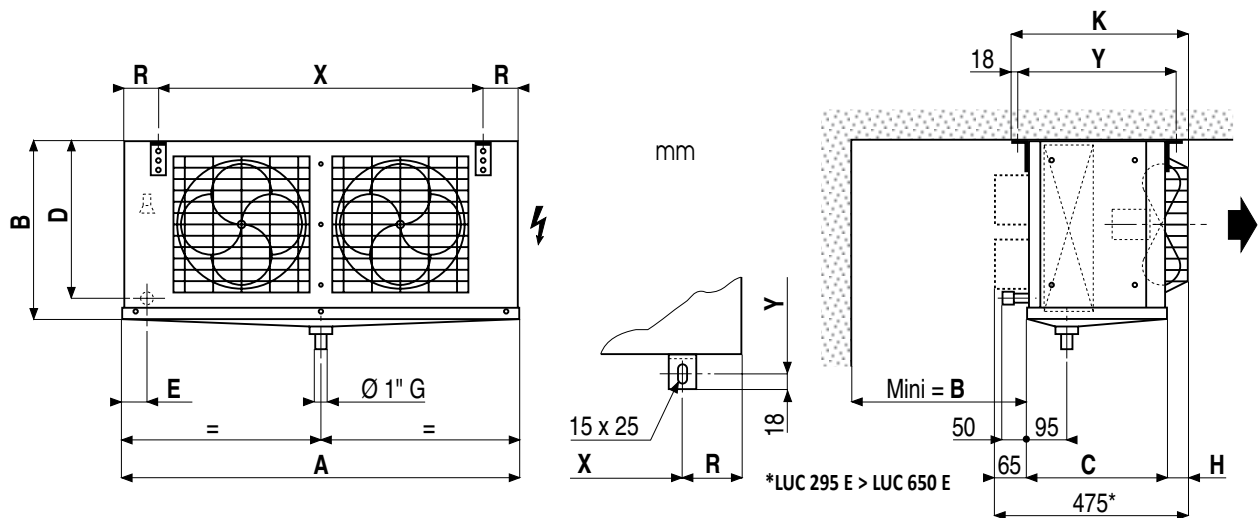

LUC ... E	BAE	WCO	CO ₂	2TH	HG1	ECK	ECU	E1K	E1U	M60*	MM5*	EEC
	-	-		0	0	0	0	-	-	0	0	0

* Only three-phase motors

LUC ... C

6,35 mm

		LUC ... C	150	205	290	345	435	545	645	695	705	715	835	1025	
Capacity	DT1 = 7 K - SC3 (1)	kW	1,30	1,67	2,48	2,78	3,58	4,39	5,17	5,68	6,21	7,08	8,38	9,64	
	DT1 = 6 K - SC4 (1)	kW	1,03	1,31	1,96	2,20	2,83	3,48	4,11	4,76	5,18	5,89	6,61	7,62	
Surface		m ²	5,17	7,54	9,33	11,66	15,98	18,64	22,43	27,80	33,70	33,70	28,04	33,65	
Circuit volume		dm ³	1,5	2,3	2,5	3,3	4,4	5,0	6,0	6,9	8,4	8,4	7,5	9,0	
Air flow		m ³ /h	1217	1239	2267	2075	2561	3250	3694	3435	3624	4436	7093	7893	
Fan	Air throw (2)	m	12	12	12	12	12	12	12	12	12	12	28	45	
	Num. x Ø	mm	1 x 300	1 x 300	2 x 300	2 x 300	2 x 300	3 x 300	3 x 300	3 x 300	3 x 300	4 x 300	2 x 400	2 x 450	
	50-60 Hz 1500 r.p.m.	230 V/1/50 Hz	W Total	145	145	290	290	290	435	435	435	435	580	-	-
			A Total	0,85	0,85	1,70	1,70	1,70	2,55	2,55	2,55	2,55	3,40	-	-
400 V/3/50 Hz	W max	-	-	-	-	-	-	-	-	-	-	-	2 x 360	2 x 360	
	A max (3)	-	-	-	-	-	-	-	-	-	-	-	2 x 1,0	2 x 1,0	
Electric defrost	Coil	Num.	2	2	5	5	5	5	5	5	5	5	5	8	
	Drain pan	Num.	1	1	1	1	1	1	1	1	1	1	1	1	
		W Total	2150	2150	3000	3000	3600	3600	5640	6900	8400	8400	5640	8460	
	230 V/1/50 Hz	A Total	5,7	9,4	-	-	-	-	-	-	-	-	-	-	
	400 V/3/50 Hz	A Total	-	-	4,4	4,4	5,2	5,2	8,2	9,9	12,1	12,1	8,2	12,2	
Dimensions	Net weight	kg	16	18	22	27	32	43	44	57	69	71	63	73	
	A	mm	575	575	981	981	1235	1355	1665	1998	2348	2348	1657	1657	
	B	mm	400	464	400	400	400	464	400	400	400	400	495	590	
	C	mm	365	365	365	365	365	365	365	365	365	365	482	482	
	D	mm	355	419	355	355	355	419	342	340	340	340	442	538	
	E	mm	42	39	89	89	89	89	110	110	110	110	110	110	
	H	mm	53	53	53	53	53	53	53	53	53	53	68	78	
	K	mm	456	456	456	456	456	456	456	456	456	456	456	596	606
	R	mm	72	72	122	122	122	182	147	147	147	147	147	147	
	X	mm	416	416	722	722	976	976	1356	1686	2036	2036	1356	1356	
	Y	mm	412	412	412	412	412	412	412	412	412	412	536	536	
Inlet	Ø (5)	D 1/2"	D 1/2"	D 1/2"	D 1/2"	D 1/2"	D 1/2"	D 1/2"	D 7/8"	D 7/8"	D 7/8"	D 7/8"	D 1 1/8"	D 1 1/8"	
Outlet	Ø ODF (6)	5/8"	5/8"	3/4"	3/4"	7/8"	7/8"	1 1/8"	1 1/8"	1 1/8"	1 1/8"	1 1/8"	1 3/8"	1 3/8"	

- (1) See pages "APPENDIX".
- (2) Residual air velocity: 0.25 m/s, in accordance with norm.
- (3) Setting of overload protections. For room temperatures 't_i' other than +20 °C, multiply the given amperage by the ratio 293/(273 + 't_i') so as to obtain the approximate amperage after the room pull down.
- (5) Liquid distributor: male to be brazed.
- (6) ODF: female sweat type connection.

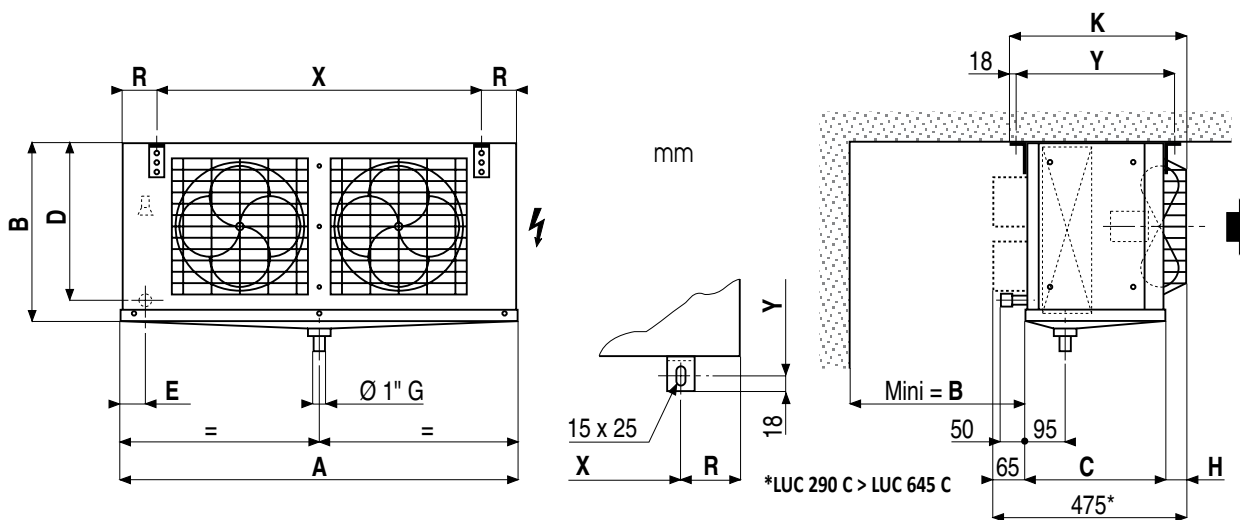

LUC ... C	BAE	WCO	CO ₂	2TH	HG1	ECK	ECU	E1K	E1U	M60*	MM5*	EEC
	-	-	☺+☺	0	0	0	0	-	-	0	0	0

* Only three-phase motors

Selection factors

Standard conditions

Standard conditions	t _{A1} Air inlet temp.	t _e Evaporating temp.	Standard DT1
SC 1	+10 °C	0 °C	10
SC 2	0 °C	- 8 °C	8
SC 3	-18 °C	-25 °C	7
SC 4	-25 °C	-31 °C	6
SC 5	-34 °C	-40 °C	6

Wet coil factor

Standard conditions	Relative humidity %	Nominal capacity / Standard capacity
SC 1	85	1,35
SC 2	85	1,15
SC 3	95	1,05
SC 4	95	1,01

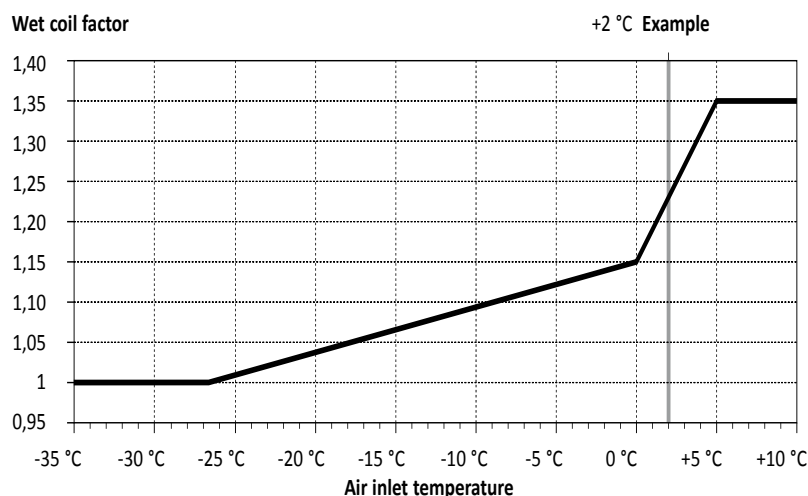

Correction for temperature differences

For refrigerant with low (below 1K), or no glide, the capacity shall be assumed to vary directly with the temperature difference between the entering air and dew point evaporating temperature i.e: Required capacity = Nominal capacity wet x Required DT1/Standard DT1.

Refrigerant factor

Refrigerant	R 404A/R 507	R 22	R 134a
SC 1	1	0,95	0,93
SC 2	1	0,95	0,91
SC 3	1	0,95	0,85
SC 4	1	0,95	-

Fin material factor

Aluminium fin	Coated aluminium fin	Copper fin
1	0,97	1,03

Example

Given:
 Required capacity **Q = 6000 W**
 Air inlet temperature **t_{A1} = +2 °C**
 Evaporating temperature **t_e = -8 °C**
 Refrigerant **R 22**
 Coil with coated fins
 solution : **DT1 = tA1 - te = (+2)-(-8) = 10K**

For a selection in standard conditions, the following correction factors must be applied :
 - wet coil factor **1,15/1,23 = 0,935**
 - correction for temp. difference **8/10 = 0,8**
 - refrigerant factor **1/0,95 = 1,05**
 - fin material factor **1/0,97 = 1,03**

Expressed in the standard conditions, the required capacity of 6000 W becomes :
6000 x 0,935 x 0,8 x 1,05 x 1,03 = 4854 W
MUC 420 R unit cooler is selected.

On board units

Our machines are fixed. Within a refrigeration system, they can be made to vibrate by motors, compressors, diesel, engines, vehicles, etc... It is the user's responsibility to make sure that the vibration is never excessive enough to cause breakage (particularly in the case of on-board systems).

EEC option

Fully Equipped Unit Cooler

The unit coolers of the commercial range can be equipped on request with the following components :

Standard condition SC2 and SC3

MR

- Expansion valve fitted
- Solenoid valve fitted
- Ball valve fitted
- Piping equipped (copper trap assured by the header) with a ball valve fitted



MH

- Expansion valve fitted
- Solenoid valve fitted
- Ball valve fitted
- Piping equipped (copper trap assured by the header) with a ball valve fitted



TA (4P)

- Expansion valve fitted
- Solenoid valve fitted
- Ball valve fitted
- Piping equipped (copper trap assured by the header) with a ball valve fitted



MUC-LUC

- Expansion valve fitted
- Solenoid valve fitted
- Ball valve fitted
- Copper trap equipped with a ball valve delivered unfitted



SD

- Expansion valve fitted
- Solenoid valve fitted
- Ball valve fitted
- Copper trap equipped with a ball valve delivered unfitted



SKB

- Expansion valve fitted
- Solenoid valve fitted
- Ball valve fitted
- Copper trap equipped with a ball valve delivered unfitted



Standard condition SC1

TA (6P)

- Expansion valve fitted.
- Solenoid valve fitted.
- Ball valve fitted.
- Piping equipped (copper trap assured by the header) with a ball valve fitted.
- Pressure control valve delivered unfitted

